

MEETING — AGENDA —

Ngā Take

www.westernbay.govt.nz



REGULATORY HEARINGS COMMITTEE

Komiti Whakariterite Kōrero

Additional Item
RH17
Thursday, 18 April 2019



Open Items

Regulatory Hearings Committee No. RH17

Additional Item

Pages

Schedule of Contents

- | | | |
|----|--|------|
| 1. | Statement of Evidence - Shae Crossan - 394 Te Puke Quarry Road
Subdivision Consent Application - 394 Te Puke Quarry Road - Te
Puke | 3-55 |
|----|--|------|

IN THE MATTER

of the Resource Management Act 1991 ("**Act**")

AND

IN THE MATTER

of an application made by 394 Te Puke Quarry Road pursuant to Section 88 for subdivision consent, land use consent and cancellation of existing consent notices at 394 Te Puke Quarry Road, Te Puke

STATEMENT OF EVIDENCE OF SHAE CROSSAN

STATEMENT OF EVIDENCE OF SHAE CROSSAN

CONTENTS:	PAGE
1. Introduction	3
2. Background	4
3. Statutory Considerations Required by the Act	7
4. Submissions & Affected Party Approvals	8
5. Actual and Potential Effects of the Proposal	12
6. Policy and Plan Provisions	19
7. Part 2 Matters	23
8. Officers Report	24
9. Conclusions	31

ATTACHMENTS:

- Appendix A Alternative Scheme Plan
- Appendix B Legal Advice for Right of Way
- Appendix C Roding X-Sections
- Appendix D Proposed Condition Suite

1. INTRODUCTION

Qualifications and Experience

- 1.1 My full name is Shae Matenga Crossan. I hold the qualifications of Bachelor of Geography (2003) and Masters of Regional & Resource Planning (2005) from the University of Otago. I am a full member of the New Zealand Planning Institute.
- 1.2 I am an Associate Principal and Senior Planner at Stratum Consultants Ltd, a planning, engineering and surveying company. I undertake planning and resource management work within the practice and have over 14 years work experience. The Company operates within the Bay of Plenty, and I have personally worked within the Bay of Plenty since 2008.
- 1.3 I have experience with a number of planning projects in the wider Bay of Plenty area including various subdivision activities and land use consents within the rural, residential, industrial and commercial sectors.
- 1.4 I am familiar with the site having undertaken a number of site visits, and the locality in general.
- 1.5 The planning assessment submitted with the application for the consents sought was prepared by Mr Jared Bartlett of Stratum Consultants Ltd under my supervision and review. Mr Bartlett is unavailable to present evidence today having left Stratum Consultants Ltd.

Code of Conduct

- 1.6 I have read and am familiar with the Code of Conduct for Expert Witnesses in the current Environment Court Practice Note (2014). I have complied with it, and I will follow the Code when presenting evidence to the Commissioner. I also confirm that the matters addressed in this Statement of Evidence are within my area of expertise, except where I am relying on the opinions or evidence of other witnesses. I have not omitted to consider material facts known to me that might alter or detract from the opinions I have expressed.

2. BACKGROUND

- 2.1 The applicant has sought consent from the Western Bay of Plenty District (“**Council**”) for a lifestyle subdivision of the subject property. The proposed subdivision will result in 32 lifestyle titles in total, one road allotment to vest, one local purpose reserve to vest and six local purpose reserve walkways to vest. Twenty-seven additional lifestyle allotments will be created in total.
- 2.2 A number of pre-lodgement/package of plans meetings commencing in June 2017 were held with Council staff prior to the submission of the formal application to Council in August 2018. Matters discussed at these meetings included proceeding with a consent application ahead of a formal structure plan being incorporated into the District Plan, traffic and access, services, walkways to facilitate public access and landscape requirements.
- 2.3 The “site” currently includes five existing titles owned by five different parties. The owners of these properties are John & Jenny Dohnt, Warren & Naomi Dohnt, Dave & Paulette Brown, Tony & Cath Morgan and Ricky & Micaela Bray. These parties are the “applicant” as a whole.

Status of the Application

- 2.4 The subdivision component of the application is a Non-Complying Activity under Chapter 17 of the Operative Western Bay of Plenty District Plan (“**ODP**”) for subdivision not in accordance with an approved structure plan, or where no structure plans exists and allotments not meeting the minimum lot size.
- 2.5 As a portion of the subject site is within an identified landscape area, consent is required to subdivide within this feature as a Restricted Discretionary Activity under Chapter 6 of the ODP.
- 2.6 Consent is also required for under width privateways and an under width portion of the proposed road to vest as a Restricted Discretionary Activity under Chapter 12 of the ODP.
- 2.7 The overall activity status of the subdivision is therefore a Non-Complying Activity.

- 2.8 I note that in Consultant Planners Sec 42A Report, Mr James Danby also states that consent is required under the National Environmental Standard for Assessing Soil Contamination in relation to the Protect of Human Health (NESCS) for subdivision of a “piece of land” as a Discretionary Activity. Whilst I do not disagree with the fact that some of the land is a “piece of land” as it contains developed kiwifruit orchard, I am of the opinion, which is also supported by the Mr Alan Woodger of Stratum Consultants Ltd who prepared the PSI report, that the subdivision itself is a permitted activity pursuant to Section 8(4) of the NESCS as there is no change of land use until such time as residential use occurs on the land.
- 2.9 Overall I do not consider it a major contention as suitable conditions of consent have been imposed regardless of whether or not consent is required, however in my view it is important to ensure that the correct consents are reflected as part of any legal consent decision.
- 2.10 Furthermore, I confirm that consent is sought to cancel/vary existing consent notices pursuant to Sec 221 RMA on some of the subject titles relating to geotechnical requirements that will be superseded by updated geotechnical information submitted as part of the consent application.

Scope and Summary of Evidence

- 2.11 I have prepared this evidence to help answer the key planning questions relating to the Application. In particular, I summarise the nature and significance of effects (drawing upon the information in the specialist traffic, landscape and engineering reports), and I provide my assessment of the relationship of the proposal with the provisions of the relevant planning instruments, Section 104 and Part 2 of the Act.
- 2.12 In summary, I have concluded the adverse effects of the proposal will be no more than minor overall. I consider that overall effects from the proposed development can be appropriately mitigated by conditions of consent.
- 2.13 In addition, I have reviewed the provisions of the planning instruments that I consider are relevant to the proposal as detailed in the application. These include the Regional Policy Statement, the Regional Natural Resources Plan and the Operative District Plan.

2.14 I have concluded that granting consent to the proposal will not be contrary to the relevant objectives and policies of the planning instruments that relate to the core issues to be considered for the Application; i.e.:

- Amenity;
- Traffic & Access;
- Landscape & Character;
- Precedent

Sources of Information

2.15 My sources of information are:

- (a) The application document dated 16 August 2018 in support of the Application at hand;
- (b) The landscape and visual assessment prepared by Richard Hart Landscape Architect attached to the original application;
- (c) The transportation safety audit prepares by Harrison Transportation Ltd attached to the original application;
- (d) The geotechnical report prepared by Stratum Consultants Ltd attached to the original application;
- (e) The NESCS report prepared by Stratum Consultants Ltd attached to the original application;
- (f) The onsite effluent treatment report prepared by Stratum Consultants Ltd attached to the original application;

2.16 Mr Harrison and Mr Hart are unable to attend the hearing on 18 April 2019, however will be available by telephone for questions should the committee require clarification on any landscape or traffic related matters.

2.17 Subject to the contents of this statement, the contents of the previous assessments are confirmed.

3. STATUTORY CONSIDERATIONS REQUIRED BY THE ACT

- 3.1 Whilst I wish to avoid repeating provisions of the Act and the District Plan that are identified in Mr Danby's Section 42A report, to establish the basis of my opinions it is necessary for me to summarise the Act assessment requirements under which the application is to be considered.
- 3.2 The application is determined to be a Non-Complying activity under the Operative District Plan. The proposal is therefore to be assessed against Section 104D of the Act, in addition to Sections 104 and 104B.
- 3.3 Section 104 requires that consideration of the application shall, subject to Part 2, have regard to:
- The actual and potential effects on the environment of allowing the activity;
 - Relevant provisions of the Regional Policy Statement, the Natural Resources Plan, and the Operative WBOPDC District Plan;
 - Any other matter considered relevant and reasonably necessary to determine the application.
- 3.4 The Section 104 assessment is also subject Part 2 of the Act. I consider the relevant Part 2 matters that are required to be recognised in achieving the purpose of the Act (Section 5), and provided for in considering the Application are:
- Section 6 matters including:
 - (b) The protection of outstanding natural features and landscapes from inappropriate subdivision, use and development
 - Section 7 matters including:
 - (a) The efficient use and development of natural and physical resources;
 - (b) The maintenance and enhancement of amenity values;
 - (f) Maintenance and enhancement of the quality of the environment;
 - (g) Any finite characteristics of natural and physical resources.

- 3.5 Applying Section 104D of the Act, which is commonly referred to as “the gateway test”, a resource consent for a Non-Complying activity may only be granted if either:
- The adverse effects of the activity on the environment will be minor; or
 - The application is for an activity that will not be contrary to objectives and policies of the District Plan.
- 3.6 If the consenting authority is satisfied that either limb of the gateway test is met, the consenting authority has discretion to grant or refuse consent and in making its decision the Section 104 matters to which regard must be given are:
- The actual and potential effects on the environment of allowing the activity,
 - Relevant provisions of the Regional Policy Statement, the Natural Resources Plan, and the Operative District Plan.
 - Any other matter considered relevant and reasonably necessary to determine the application. In this case I consider that there are no other matters that need to be addressed.
- 3.7 For the purposes of this evidence, I consider the most relevant planning instruments to be the Regional Policy Statement, the Natural Resources Plan and the Operative Western Bay of Plenty District Plan.

4. Submissions & Written Approvals

- 4.1 The applicants consulted with and obtained the written approval of the owners of the properties at 394D Te Puke Quarry Road and 282D Te Puke Quarry Road who currently gain legal and physical access via existing rights of way through the properties.
- 4.2 The written approval of the owner of the property at 419 Te Puke Quarry Road was also sought and obtained due to bank trimming required to achieve sight distances at the new road/Te Puke Quarry Road intersection affecting this property.
- 4.3 Written approval was also obtained from the QE II Trust for walkways and rights of way adjoining and partially within existing QEII features on a portion of the property.
- 4.4 Consultation was undertaken with the owners of Lots 1 & 4 DPS 48352, a large Forestry syndicate who also share the existing right of way. The chairman of the committee provided a letter confirming that the committee had no objection to the

proposal and also requested additional documentation for signing given the large number of owners of that property. The additional documentation was provided as requested, however no further response was received by the applicant.

- 4.5 A total of one submission was made to the application by one property owner as part of the limited notification process. The submission was received after the closing date of the submission period on 5 February 2019 and was formally acknowledge by WBOPDC on 18 February 2019.
- 4.6 The aforementioned submission in opposition was made by **Stephen & Ruth Mayne** (owner of the property located at No. 394E Te Puke Quarry Road legally described as Lot 2 DPS 48352 and Lot 3 DPS 48352).
- 4.7 The applicant had attempted to consult with the above party prior to lodging the resource consent application and post lodgement prior to the close of submissions however I understand they advised that they would not be providing written approval to the proposed development.
- 4.8 The following provides a summary of the submission in opposition and the points raised. Where relevant I comment on some of these matters and will further address relevant RMA concerns raised in my assessment of effects and through my assessment of the relevant objectives and policies.

Stephen & Ruth Mayne – 394E Te Puke Quarry Road

- 4.9 Stephen & Ruth Mayne state that they oppose certain parts of the application including proposed car parking at the end of the new road to be vested, the proposed walkway/greenlane along their southern boundary line and the density and location of proposed lots 8 – 12 of the subdivision.
- 4.10 Firstly, in relation to the proposed car parking at the eastern end of the road to vest the submitter is concerned that this will pose a security risk and increase the likelihood of freedom camping thereby affecting the existing pristine environment in this location.
- 4.11 In relation to the proposed car parking, this location was developed in consultation with WBOPDC staff as a means of providing a mid-point parking and access area

to link to the upper and lower walkway/greenlane areas. Topographically it is the most suitable location on the proposed new road that is not limited by sloping land on either side.

- 4.12 In my opinion, with the creation of Lots 8, 9 & 10 as proposed, this will provide for passive surveillance of the end of the proposed road with houses in close proximity freedom campers would be discouraged. Furthermore, the applicant has proposed that they will install “no freedom camping” signage to discourage this activity.
- 4.13 As an alternative, the applicant has offered to relocate all proposed car parking to the southern car parking area accessed from No. 292 Te Puke Quarry Road should this be required. In my view this would be a lesser outcome in terms of public accessibility to the walkways given the proposed length and topography of the walkways, whereby the current proposed location provides a mid-point access to the upper and lower tracks.
- 4.14 With regard to the proposed walkway adjoining the Mayne’s boundary, I note at present the walkway does not adjoin their boundary, rather it directly adjoins the access leg boundary of the neighbouring forestry block (Lot 4 DPS 48352) which is approximately 9m from the submitters legal boundary. The submitters dwelling is approximately 100m beyond this point and presently screened by existing vegetation.
- 4.15 However, in considering the submitters concerns, the applicant has offered to fence the 40m length of this walkway adjoining Lot 4 DPS 48352 with deer fence and plant a 2m high vegetation strip to provide additional security and screening to mitigate the submitters concerns. A condition of consent can be imposed to this effect if required by the committee.
- 4.16 In terms of the concerns regarding proposed Lots 8 – 12 and the density and location of these lots I comment as follows. In terms of the minimum lot sizes for the zone, these are currently set at a minimum of 3000m² with an average of 5000m², or a minimum of 3000m² with an average of 4000m² where Greenlanes are created in the Minden Zone. Proposed Lots 8, 10 and 11 do not currently meet this minimum lot size, however the average lot size across the subdivision well exceeds the 5000m² and 4000m² requirements respectively being in excess of 1ha.

- 4.17 The proposed smaller lot sizes were discussed with Council staff at the initial package of plans meeting whereby it was agreed that smaller lots not meeting the minimum would be acceptable provided that the lots could adequately contain a dwelling able to comply with yard setbacks, complying access and effluent and stormwater disposal methods. Compliance with this is demonstrated on the scheme plan attached and within the respective geotechnical and OSET reports attached to the original application.
- 4.18 With respect to the allotments that the submitter is concerned with, proposed Lot 12 is well separated from the applicant's property (i.e. over 100m from the boundary and 200m to their dwelling). In terms of proposed lots 8 & 9, an alternative scheme plan is attached at Appendix A, which has adjusted proposed Lots 8 & 10 so that they are above the minimum lot size of 3000m², whilst the identified house sites have remained the same. In my opinion, there is no nett difference in effect from this complying lot size configuration to that shown on the original plan, as house sites will remain in the same position and comply with yard setback controls in relation to both external and internal property boundaries. In the context of the overall development I consider the marginal allotment size non-compliances do not compromise the intention of the zone or development as lifestyle living can be provided and accommodated on each allotment. Whilst I do not consider it necessary, should the committee require it then the alternative scheme plan with complying lots 8 & 10 could be approved if required.
- 4.19 Whilst not a submission point, the applicant's solicitors have researched the existing legal right of way access to the submitters property (Lot 2 DPS 48352 and Lot 3 DPS 48352) as per the letter attached at Appendix B. The legal advice has indicated that portion of the submitters property containing their dwelling (Lot 2 DPS 48352) does not have any legal right of way over the existing right of way access whereby they currently gain physical access to their dwelling at 394 Te Puke Quarry Road and only a portion of their title containing a small pump shed (Lot 3 DPS 48352 – 360m²) has legal rights as the right of way was not extended to Lot 2 DPS 48352 when this title was created. Whilst the applicant does not intend to enforce this, in my opinion the provision of public road frontage to this property will provide irrefutable legitimate access.
- 4.20 It is my opinion that the issues raised in the submissions have been adequately dealt with in the application, by Mr Danby in his Section 42A report and further

addressed through this hearing process by the evidence provided today. The relevant Act issues raised are further addressed in my assessment of effects below.

5. ACTUAL AND POTENTIAL EFFECTS ON THE ENVIRONMENT

5.1 In this section I address the potential adverse effects of the application which, I consider to be:

- Visual Effects.
- Traffic & Access Effects.
- Landscape & Character Effects
- Privacy Effects
- Precedent Effects
- Other Matters

5.2 The Act's definition of effects also includes positive effects and I consider the following positive effects should be considered. These include:

- The provision of a high quality rural lifestyle subdivision on currently underutilised farmland which is zoned for lifestyle development;
- The provision of public access through the proposed walkways/greenlanes

Visual Effects

5.3 The key amenity consideration in my view are the potential visual effects of locating additional houses within the landscape. Given the underlying lifestyle zoning, houses as proposed are provided for.

5.4 In terms of visual impacts, the main considerations are therefore limited to the allotments that are located within the Outstanding Landscape Feature S4 that follows the 100m contour across the subject site. Portions of Lots 1, 22, 23, 24, 25, 26, 27, 28 and 29 are located within the identified feature.

5.5 The specialist Landscape and Visual Assessment ("LVA") prepared by Mr Richard Hart, has addressed the visual effects in detail by considering the landscape context, viewing audience and catchment. Mr Hart has recommended building design controls and landscaping for Lots 23 – 29 to allow any future dwellings to "blend in" with the surrounding environment. Lot 22 already contains an existing dwelling and Lot 1 only contains a small area of the OLF. I note that Mr Danby has

recommended a consent notice condition requiring compliance with the restrictions recommended by Mr Hart with respect to the relevant allotments which I consider is appropriate.

- 5.6 In my opinion, and based on the advice of Mr Hart, the visual effects can be suitably mitigated and will be no more than minor.

Traffic & Access Effects

- 5.7 Access measures were detailed as part of the original application submitted to Council along with information submitted as part of a further information request. A transportation safety audit based on the roading concept design prepared by Harrison Transportation was also submitted with the application as is required when a road is to be vested.

- 5.8 The applicants traffic consultant, Mr Bruce Harrison, an experienced traffic engineer, has reviewed the proposed road and intersection with Te Puke Quarry Road. Mr Harrison concluded that based on traffic volumes of the local roading environment and subject to the measures described in the safety audit being undertaken, the access and traffic resulting from the development could be accommodated within the surrounding roading network and the new proposed road is fit for purpose.

- 5.9 As detailed in the application the proposed public road has a legal width of 15m except for a 12m wide section (35m long) that is limited by topography and existing structures.

- 5.10 I note that as per Condition 29 of the proposed suite of conditions, the condition requires a minimum 15m legal width for the full extent of the road corridor. Mr John Lewis of Stratum Consultants has spoken with Council's Consultant Engineer, Mr Dallas Banks regarding this and we understand that the 15m width has been requested due to the ability to co-locate services and roading fully within the corridor. I note that the only services to be located within the road corridor itself would be stormwater and electricity and telecommunications ducting as there are no other reticulated services available for proposed.

- 5.11 A cross section plan of the proposed 12m section of road is attached showing the ability to contain relevant services within the 12m wide road corridor. I also note

that this 12m section is only for a length of 35m and the 12m width is not requested for the entire length of road.

- 5.12 To put the above road widths in perspective, a rural road to cater for this level of development would require a legal width of 20m as per the Development Code. This is generally to cater for larger table drains on the sides of the road and larger carriageways. A residential road servicing up to 30 dwellings (30 properties would be served by the public road sought as part of this application) could be 12m with dispensation allowable in the Development Code. I note that the Development Code itself is a best practice guideline, however suitable alternatives can be achieved (and have previously been accepted by WBOPDC), where it has been proven that there are no safety issues and what is proposed is fit for purpose.
- 5.13 Furthermore, as detailed in the application it is sought to construct the proposed public road carriageway with a single cross fall and a width of 6m. The Development Code requires a 2 way cross fall and a 6.5m carriageway for a rural road and would require (with dispensation from Council) a 2 way cross fall and 6.0m wide carriageway. It is noted that under Section 4.3.6 of the Development Code, a single cross fall may be permitted for local roads subject to authorised office approval. As noted in the safety audit prepared by Harrison Transportation, NZS 4404:20101 "Land Development & Subdivision Infrastructure" recommends a carriageway width of between 5.5m and 5.7m to serve up to 150 units for a rural road.
- 5.14 In the case of this application there is no specific design available in the Development Code for public roading associated with lifestyle zone development and the roading proposed as part of the development is more a mix of rural and residential engineering with kerbing to control stormwater and reduce roading width due to topographical restrictions. The single cross fall as proposed has been designed to control run off from affecting the steeper downslope embankment areas by directing stormwater away from these slopes, where it can be collected and piped to a suitable disposal location.
- 5.15 The safety audit of the concept design prepared by Mr Harrison, an experienced traffic engineer and geotechnical advice from Mrs Elles Pearse Danker, a Category 1 geotechnical engineer of Stratum Consultants Ltd, have supported the single cross fall from traffic and geotechnical perspectives.

- 5.16 No issues have been raised with respect to traffic effects on the wider roading network.
- 5.17 Based on the advice of the specialist traffic engineer and geotechnical engineer, I am satisfied that access as proposed to serve the development will provide safe and efficient access which will be subject to further review through the engineering approval process.

Landscape & Character Effects

- 5.18 In my view the character and landscape effects are similar in nature to the visual effects and the proposed mitigation of this is interrelated.
- 5.19 Whilst subdivision of the rural residential lot sizes proposed as part of this subdivision represents a change to what exists at present, the type of development is envisaged by the underlying zoning. The character and landscape of the area is made up of a mixture of uses including rural residential allotments, forestry, allotments, pastoral allotments.
- 5.20 The proposed development will result in a change to the existing character and environment given there are only a limited number of houses on the proposed allotments at present. However, I concur with the assessments by Mr Hart and Mr Danby in their respective reports. that the mitigation measures proposed through the proposed conditions of consent will result in the landscape and character effects of the proposal to be minor.
- 5.21 Whilst there are five allotments below the minimum lot size of 3000m², in my opinion there is no difference in effect generated by the reduced size allotments that would otherwise be created by allotments meeting the minimum lot size and the average density across the subdivision is well within the anticipated average lot size for the zone. I note that this view is supported by Mr Danby in his Sec 42A Report.
- 5.22 Effects on the landscape and character of the area will therefore be no more than minor in my opinion and generally as anticipated by the District Plan for the zone.

PRIVACY EFFECTS

- 5.23 As previously advised, the submitter has raised concerns over privacy where the walkway is within proximity to their boundary and concerns over freedom camping at the end of the proposed new road. In my view privacy is a subset of amenity.
- 5.24 In my opinion, the proposed walkway is sufficient separated from the submitters dwelling by physical distance and also from their boundary by the access leg to the adjoining forestry property. As an additional security measure the applicant has offered to construct a deer fence along a short length of the walkway and also to plant a vegetative screening strip along this length of boundary which I consider are more than reasonable measures to address privacy concerns from the relevant section of walkway.
- 5.25 In terms of the concerns over freedom campers utilising the parking at the end of the proposed road, whilst I cannot unequivocally confirm that freedom campers will not use the parking area, I consider that they will be actively discouraged given the proximity of new dwellings on proposed lots 8, 9 and 10 and furthermore the applicant is willing to install signage preventing freedom camping.
- 5.26 I note that Mr Danby has also outlined two bylaws with respect to freedom camping and Councils ability to control this. I consider that this provides further measure for the prevention of freedom camping at the end of the proposed public road.
- 5.27 As I have noted earlier, there are alternatives for car parking with additional carparks in the lower area of the property at No. 292 Te Puke Quarry Road, however in my view this does not provide the best outcome for accessibility and linkages to the proposed public walkways.

PRECEDENT

- 5.28 As a non-complying activity, it is important that the matter of precedent is addressed. A precedent effect is a concern that similar applications for consent should be dealt with in a similar way. It is not an effect on the environment but may be a matter for Council to consider under the any other relevant matters clause of section 104.

- 5.29 Granting consent to a non-complying activity has no precedent effect in the strict sense as each application has its own particular set of circumstances and characteristics in relation to location, topography, soils, access, drainage, surrounding land use, etc. The RMA requires applications to be considered on their own merits. The extent of influence that this proposal might have on other applications will entirely depend on the similarities and the timing with respect to the District Plan assessment
- 5.30 This proposal involves the subdivision of a property that has been zoned for such development. The non-complying status is generated by provisions in the District Plan requiring a structure plan to be prepared, undersized allotments and access restriction to the former State Highway (that have now been relieved through physical construction works and the fact that the Te Puke Highway is now administered by WBOPDC and no longer a State Highway). Granting consent to this application will not prohibit other development in this lifestyle zone, will utilise land zoned for such purposes, and does not create adverse amenity, traffic, or character effects.
- 5.31 I am not aware of any other applications of this nature or scale that have been made in the period of the current District Plan, even within the Minden Lifestyle Zone which has seen considerable lifestyle development over recent years. The lifestyle zones across the District are relatively discrete areas and have been zoned for such purposes since the current District Plan was made Operative in 2012. The application does not draw support from any earlier precedent-setting application and likewise there can be no assumption that this application will establish a precedent for other applications going forward.
- 5.32 For the reasons above I agree with Mr Danby when he concludes that the proposal under consideration can be distinguished from any new application that may be lodged and precedent is not a concern in terms of the application at hand.

Other Matters

- 5.33 In terms of ecological effects, as noted in the application and addressed by Mr Danby, a portion of the subject sites is subject to an existing QEII covenant area. No native vegetation is proposed to be removed and consultation has been undertaken with QEII, who have subsequently provided their written approval to the

proposal. I therefore consider that relevant ecological effects have been assessed and accepted.

- 5.34 With regard to historic heritage, Mr Danby notes that Heritage New Zealand (HNZ) and Waitaha were notified of the application through Councils standard referral process. HNZ correctly notes that all archaeological matters are subject to the provisions of the HNZ PHT Act which is acknowledged by the applicant. Mr Danby also notes that Waitaha did not provided any comment on the application and that there is no statutory acknowledgement within or close to the site.
- 5.35 In terms of contaminated land, it is acknowledged that there are areas of developed kiwifruit orchard within the property. A preliminary site investigation (PSI) report has been prepared which confirms that the subdivision itself does not pose any risk to human health, a view supported by Mr Danby. I agree with this assessment and consider that it is more appropriate to fully address contamination on the relevant allotments at the time of building consent when a specific house site is chosen on those respective allotments. I support the inclusion of a consent notice to this effect as proposed by Mr Danby.
- 5.36 With respect to the consent notice cancellation, these existing consent notices are subject to internal parties as part of the application only and will be subject to replacement by new geotechnical information which will supersede the previous information. I consider it appropriate that this is provided for to avoid any future confusion over relevant matters as if these consent notices were not cancelled they would transfer onto the new titles.

Overall Opinion on Effects

- 5.37 I agree with the reporting planner, Mr Danby's assessment of effects and conclusion that effects resulting from the subdivision will be no more than minor overall.
- 5.38 Relying on the LVA report of Mr Richard Hart, information provided by the applicant, traffic and access advice provided by Mr Bruce Harrison, the geotechnical, effluent and contaminated soils reporting, as well as my own personal observations of the site and its surrounds, it is my opinion that any potential adverse effects of the proposal will be no more than minor overall, subject to the proposed suite of recommended conditions being imposed.

5.39 In my view the first arm of the Section 104D “Gateway test” is met.

6. POLICY AND PLAN PROVISIONS

6.1 In this section of my evidence I comment on the provisions of the relevant planning instruments and provide my opinion with respect to the consistency of the proposal against them. In this case, I consider the relevant instruments to be:

- The Regional Policy Statement (“**RPS**”)
- The Regional Natural Resources Plan (“**RNRP**”)
- The Regional On Site Effluent Treatment Plan (“**ROSETP**”)
- The Operative Western Bay of Plenty District Plan (“**ODP**”)
- The National Environmental Standard for Assessing Soil Contaminants in Relation to Human Health (“**NESCS**”)

6.2 I consider the main issues arising for the Application are:

- Character & Amenity
- Traffic & Access
- District Plan Integrity

6.3 Mr Jared Bartlett who prepared the original application, has set out what I believe to be the relevant objectives and policies in the original application and Mr Danby has also covered these in his Section 42A report. I will expand on the assessment of these in relation to the above matters where necessary, however to avoid repetition I do not consider it necessary to provide detailed further assessment where I agree with My Danby.

RPS & RNRP Matters

6.4 The RPS specifically sets out objectives and policies for urban and rural growth, and land use that I consider relevant and are the key issues required to be addressed as part of this proposal.

6.5 The RNRP specifically sets out objectives, policies and rules for activities that have the potential to affect water and land resources (i.e. earthworks, stormwater)

- 6.6 The ROSETP specifically sets out objectives, policies and rules for onsite effluent treatment where no reticulated sewer system is available.
- 6.7 Mr Bartlett undertook a detailed analysis of the relevant Operative District Plan objectives and policies relating to the development in the application (Section 5).

Character & Amenity

- 6.8 I consider that amenity and character are directly related in the context of the proposed subdivision and the relevant objectives and policies are therefore interrelated.
- 6.9 In my opinion the relevant objectives and policies of the ODP with regard to character and amenity relate to Chapter 6 Landscape (Objective 6.2.1 & Policy 6.2.2), Chapter 12 Subdivision (Objective 12.2.1(1)) and Chapter 17 Lifestyle Zone (Objectives 17.2.1(1), 17.2.1(2))
- 6.10 The above objectives and policies generally seek to maintain the landscape character and visual aspect/amenity of the area and provide for lifestyle development sympathetic to the landscape and surrounding environment.
- 6.11 In my view the proposed activity is not contrary to these provisions. Whilst there will be a change to the character of the landform that exists at present, the underlying zoning of the site anticipates lifestyle development and specific design controls are proposed in relation to those allotments that site within the identified landscape feature.
- 6.12 Whilst there are a small number of allotments not meeting the minimum lot size, the average lot size is well in excess of that envisaged by the zoning.
- 6.13 Each proposed house site is located so as to comply with the minimum yard provisions in relation to existing external boundaries and proposed new internal boundaries and therefore the separation distances envisaged are maintained.
- 6.14 In my opinion, amenity and character effects generated by the proposal can be suitably mitigated and the proposal is therefore consistent with the relevant objectives and policies in relation to amenity and character.

Traffic, Access & Transportation

- 6.15 The relevant objectives and policies of the ODP relating to traffic matters associated with this proposal in my opinion are generally those found in Chapter 4 – Transportation, Chapter 12 – Subdivision and Chapter 17 – Lifestyle. More specifically Objectives 4B.2.1(2) and Policy 4B.2.2(2), Policy 4B.2.2(7), Objective 12.2.1(2), Objective 12.2.1(3), Objective 12.2.1(4), Objective 12.2.1(5) and Policies 12.2.2(1), 12.2.2(4), 12.2.2(5) and Policy 12.2.2(9). In addition, Lifestyle Zone Objectives and Policies 17.2.1(1), 17.2.1(3), 17.2.2(1), 17.2.2(8), 17.2.2(10) are also relevant.
- 6.16 The above objectives and policies broadly aim to ensure that safe and efficient vehicle access and manoeuvring is provided to allotments as a result of subdivision and that effects on the wider transportation network are minimised.
- 6.17 Access and the effects on the transportation network of the activity have been assessed and accepted by Councils Roading Consultant and the applicants Traffic Consultant Mr Harrison, subject to the mitigation as detailed and recommended by Mr Danby in his suite of consent conditions. Detailed engineering design of the roading is required which will allow for further assessment at that stage.
- 6.18 Whilst the proposed road design is not specifically in accordance with the Development Code, the Policies of Chapter 12 specifically allow for alternative design which is effective and efficient in the long term.
- 6.19 Each allotment is large enough to provide efficient parking and vehicle manoeuvring.
- 6.20 In my opinion, the application is consistent with the relevant transportation objectives and policies

District Plan Integrity

- 6.21 The RMA has made provision for non-complying activities which by their nature do not comply with rules of the Plan. It is therefore not the rule which is the critical consideration. Section 104 requires that there is an assessment against the objectives and policies, i.e. what is it that the rules are trying to achieve. The rules

are not an integral part of objectives and policies but may be one mechanism for establishing consistency with objectives and policies. The non-complying category provided by the RMA does not discount that there are other possibilities.

- 6.22 Whilst the proposal does not comply with the “rules”, it is my opinion that this is a technicality in that the non-compliance is generated from no structure plan being currently in place and provisions of the District Plan relating to intersection upgrades at Manoeka Road and Te Puke Quarry Road as well as NZTA approval.
- 6.23 As I have previously alluded to, the Te Puke Highway is now under the jurisdiction of WBOPDC with the TEL providing the new State Highway access. Furthermore, the physical safety works have since been undertaken at the aforementioned intersections.
- 6.24 Proceeding ahead of a structure plan process does not prejudice or prevent other parties from developing their land within the zone and relevant matters requiring assessment through a structure plan (i.e. roading and reserve networks and linkages) have been fully addressed through the consent application at hand.
- 6.25 Whilst a small number of allotments do not meet the minimum lot size also triggering consent for a non-complying activity, given the scale of the proposal combined with the average density of development across the subdivision and the ability to comply with relevant bulk and location and servicing requirements I consider that this is of minimal consequence in terms of the overall development.
- 6.26 As I have assessed above, in my opinion the proposal achieves the intentions of the relevant objectives and policies by providing for lifestyle development of land zoned for such purposes and that District Plan integrity is upheld overall given the circumstances as described above.

Overall opinion on provisions of planning instruments

- 6.27 In my opinion the proposed subdivision is not contrary to provisions of relevant planning instruments. Effects of the activity can be suitably mitigated which uphold the intention of the relevant objectives and policies and the intent of the zoning.

6.28 The proposal is not directly contrary to provisions of the relevant documents and accordingly, in my opinion it would be appropriate to grant consent giving due consideration to provisions of the planning instruments.

6.29 In my view the second arm of the Section 104D "Gateway test" is also met.

7. PART 2 MATTERS

7.1 In Section 3 of this evidence I set out the Part 2 matters that are to be recognised and provided for or given regard to in the decision on the Application. The provisions of the planning instruments and in particular the ODP has taken account of the Section 6, Section 7 and Section 8 requirements. An assessment of the Application against objectives and policies of the relevant instruments will also generally provide an appropriate assessment against the Part 2 matters.

7.2 The Part 2 matters indicate the need to consider potentially conflicting matters, i.e. the effective use and development of physical resources against the maintenance and enhancement of the quality of the environment.

7.3 In my opinion, the Part 2 matters and the provisions of the planning instruments provide for a broad comparison of the competing considerations and an assessment of the scale and degree of effects. I am of the view that the proposed development is an efficient use of the land resource and amenity and character effects are minimised, and that granting consent would therefore be consistent with the Section 7 matters.

7.4 Section 8 has been given regard to. No specific Treaty of Waitangi matters have been raised.

7.5 The proposed subdivision provides for the economic and social wellbeing of the applicant, will provide high quality lifestyle living for members of the public, and is an appropriate use of the land resource. In my opinion the development, subject to appropriate conditions and mitigation measures as proposed, will promote the sustainable management purpose of the Act.

8. OFFICERS REPORT

- 8.1 I have read the Section 42A report of consultant planner Mr Danby and I agree with his recommendation to grant consent.
- 8.2 I agree with Mr Danby's assessment of the relevant planning instruments and associated objectives and policies, and his assessment of potential effects arising from the development.
- 8.3 I consider that the majority of conditions proposed by Mr Danby are appropriate and will adequately mitigate potential effects of the proposal. However, I consider that some modification is required, as follows.
- 8.4 Condition 5(c) currently which relates to geotechnical requirements to be addressed as part of a geotechnical completion report, states:

That earthworks shall be undertaken as required to provide a building platform for each allotment which is suitable for the erection thereon of residential buildings providing ultimate bearing capacities greater than 300 kPa in accordance with NZS 3604 and/or that certification for each residential Lot is provided in accordance with NZS 4404 (Appendix B). At the discretion of the Chief Executive Officer or duly authorized officer, consent notices may be registered on the Lots where specific foundation type such as piles are required because of UBC is less than 300 kpa.

In my reading of the above condition, this assumes that earthworks will be undertaken on all allotments to provide a suitable building platform. This was originally the intention of the applicant; however, it is no longer their preferred option. As such, I consider that the condition should be modified so that where earthworks are undertaken they should meet the above requirements. Accordingly, I consider the condition should be modified as follows:

That where earthworks ~~shall are~~ be undertaken to provide a building platform on ~~for each an~~ allotment, they shall be suitable for the erection thereon of residential buildings providing ultimate bearing capacities greater than 300 kPa in accordance with NZS 3604 and/or that certification for each residential Lot is provided in accordance with NZS 4404 (Appendix B). At the discretion of the Chief Executive Officer or duly authorized officer, consent notices may be registered on the Lots where specific foundation type such as piles are required because of UBC is less than 300 kpa.

- 8.5 Condition (8) requires that electricity and telecommunication reticulation shall be installed to serve the subdivision. As stated in the application, it is proposed to

install electricity reticulation to serve the subdivision, however it is not proposed to install telecommunications infrastructure. The only telecommunications infrastructure currently available in the locale is a copper network which is considered redundant given wireless, satellite and mobile broadband coverage is now available. There are currently no fibre networks available to connect to. In my opinion it is uneconomic to require telecommunications to be installed with redundant technology and given the prevalence of mobile phones and wireless/satellite internet options. Ducting can be installed within the roading network should fibre become available in future. As such I consider that Condition 8 should be amended as follows:

8. THAT ~~power and telecommunications~~ electricity reticulation shall be installed to serve the development with the capacity and ability to later provide all proposed Rural lots with individual connections (lead in's). Letters are required from the electricity ~~power and telecom~~ authorities confirming that this condition has been met to their satisfaction. In addition, ducting shall be provided for fibre reticulation should this become available.

8.6 Condition (9) correctly identifies that detailed engineering design drawings are required to be submitted for approval for relevant infrastructure. In this case the only infrastructure to be vested are the proposed road and walkways. The conditions currently also refer to watermain requirements, however there is no public water reticulation to be created as part of the subdivision. Accordingly, I consider that the condition should be modified as follows:

*9. THAT the consent holder's representative shall submit to the Chief Executive Officer or duly Authorised Officer for approval, with the appropriate engineering inspection fee; construction drawings, specifications, calculations and project cost estimate; covering all sections of work which it is proposed to be built in **accordance with Council's Development Code** and vest in Council. Construction shall not commence until written approval of the plans and specification has been provided by Council. ~~Where watermains are to be vested in Council, the disinfection methodology to be used shall be incorporated in the engineering specifications. No pressure testing of watermains or sewer pipes, which are to be vested in Council, shall be observed by a Council official, unless prior written approval of the plans and specification have been provided by Council.~~*

8.7 Condition (11) requires that asbuilts drawings and information are required for all vested assets and service connections. It also contains a clause requiring asbuilts that may be required. The only works which will be vested are the proposed road

and stormwater reticulations/pipes within that road and as such I consider the condition should be modified as follows:

11. THAT as-built information and drawings shall be provided for all vested assets and service connections ~~(or other works that may be required to be as-built— e.g.: earthworks—[the Development Engineer to specify])~~ in accordance with Council's Development Code.

- 8.8 Condition (13) requires that at the end of the maintenance period, all maintenance items are required to be certified as complete. The condition is acceptable however there are no footpaths within the public road and I therefore suggest the condition is amended to remove footpaths as follows:

13. THAT at the end of the maintenance period, all maintenance items are required to be certified as complete including that the berms have been mown, carriageways ~~and footpath~~ swept and catchpits cleaned by the consent holder's representative.

- 8.9 Condition (29) requires that the proposed public road has a legal width of a minimum of 15m. As I have described earlier in the assessment of effects, there is a short length (35m) of the road to vest that has a proposed legal width of 12m due to topographical and existing building constraints. A subsequent telephone discussion between Mr John Lewis of Stratum Consultants and Councils Consultant Engineer Dallas Banks identified concerns with the 12m legal width section of the proposed road and its ability to fully contain the proposed road and associated services. To that end a surveyed cross section has been prepared confirming that the roading and relevant services can be contained within this 12m width. As such, based on this I am of the view that this short section of 12m legal reserve is acceptable. Accordingly, I consider that the condition can be amended as follows:

29. THAT a minimum 15m wide road reserve corridor (except the 12 wide section as shown on Stratum Consultants Ltd Plan 415542-T-S-D001, Sheet 06, Issue A) shall be vested over the proposed road alignment but the width shall also include all existing / proposed cut and fill batters and any sight distance splays in accordance along the road alignment with Council's

Development Code. This may require the proposed road reserve boundary to be moved to accommodate the above criteria.

- 8.10 Condition (30) requires that the proposed public road has a carriageway with a two way cross fall and also notes that a 5.5m carriageway can only serve up to 200 vehicle movements per day. As I have discussed earlier, the proposed carriageway is single cross fall, with a carriageway of 6m wide reducing to 5.5m wide which has been supported by specialist traffic engineer Mr Harrison in his Transportation Safety Audit. As such, I consider that Condition 30 can be amended as follows:

*30 The design of the proposed Road Lot 34 shall comply with Council's District Plan and Development Code requirements **including Council's standard drawing number W417**, except as follows:*

- a) Carriageway widths shall be 6.0m wide and 5.5m wide. ~~A 5.5m carriageway can only serve a maximum ADT of 200 vehicle movements per day.~~*
- b) A road with a centre line and ~~2-way~~ single cross fall shall be provided ~~in accordance with Council's standard drawing number W417.~~*

- 8.11 Conditions 34, 52, 63 & 74 require relevant vehicle entrances to be constructed in accordance with Council Standard Specification Drawing No's W436 & W437. This is correct, however I consider that as the development is a lifestyle development then the applicable lifestyle vehicle entrance standard (Diagram C) should be referenced as follows for clarity and the relevant conditions updated:

THAT sealed vehicle entrances to serve all confined vehicle entrance locations, all the existing entrances served from Lot 34 and all the proposed privateways shall be constructed in accordance with Council's Standard Specification Drawing No's W436 and W437 (Diagram C). ~~The entrance shall be sized in accordance with Drawing number W437. A culvert shall be installed to convey stormwater and to protect the Council road, alternatively at the developer's representative discretion and approved by Council, the culvert can be substituted by a swale being constructed to the same contour as the existing table drain. Where the vehicle entrance adjoins a kerb and channelling a 1.2m deep Commercial apron shall be provided in accordance with drawing number W435 and W436.~~

- 8.12 Condition (37) currently requires an easement to be created over proposed Lot 32 as shown on the scheme plan to protect sight distances. In my opinion this is more appropriate as a covenant as has been included the area of Part Section 28 SO 7648 at the intersection. I suggest the condition is changed as follows:

37 THAT ~~an easement~~ a covenant be created over proposed Lot 32 and any other allotment to include the clear line of sight from the proposed vehicle entrances to serve Privateway EA by Transfer in accordance with the approved format.

- 8.13 Conditions 38, 53, 64 & 75 currently require that all privateways are constructed in accordance with the Development Code and the District Plan which I consider is generally appropriate. However, there may be circumstances where topography does not allow for strict compliance and a minor variation is necessary. In my view this can be assessed at the time of detailed design and engineering approval. As such, I consider that the condition should include the ability for a Council officer to approve non-compliances at their discretion. Accordingly, I consider that additional working should be added to these conditions as follows:

*THAT the proposed Privateways ***** shall be constructed in accordance with Council's Standard Specification Drawing No's W439 and W440, or subsequent design to be approved at Councils discretion at the time of engineering approval. The type of surface to be provided (sealed or unsealed) shall be assessed at the engineering documents stage and shall comply with Council Minden Lifestyle rules and shall comply with the District Plan Rule in respect to neighbour's consent to unsealed surfaces.*

- 8.14 Condition (40) requires easements to be created over any stormwater main on affected allotments in favour of Council. I suggest the condition is changed to include pipes or overland flowpaths as follows as there are no proposed stormwater mains and that this is only limited to stormwater from the vested road.

40. THAT a storm water easement shall be created over any the storm water pipe or overland flowpath resulting from the vested road ~~main~~ on the affected allotments in favour of Council as dominant tenement and that this be shown on the survey plan.

- 8.15 Condition (41) currently requires the consent holder to confirm that all necessary consents from BOPRC in relation to the subdivision have been granted, where in future WBOPDC would become the consent holder that all conditions are acceptable, and that confirmation is provided from BOPRC that works required by these consents have been completed to their satisfaction. In my view the wording

of the condition is currently inappropriate as it assumes that consents will be required from BOPRC and also relies on external party input to confirm that the condition is satisfactorily met, which is beyond the applicant's powers of control. In many previous consent applications, I have been involved in within the WBOPDC District, additional consents have also been required from BOPRC however there has been no condition imposed that requires BOPRC consents to be obtained prior to the commencement or fulfilment of that specific District Council Consent. The onus and legal obligation is on the applicant to ensure that all necessary consents are obtained. Any consents required from BOPRC would likely relate to earthworks, stormwater discharge and potentially works to replace the two bridges within the relevant privateways, however I cannot confirm this until further detailed design has been completed. Any consents from required from BOPRC are addressed separately under the Regional Natural Resources Plan. As such, I do not consider that it is appropriate to impose a condition to this effect and that the condition should be deleted as it stands.

- 8.16 I do agree however that WBOPDC would need to be agreeable to any consent conditions (i.e. permanent stormwater discharge from the road to vest) if they were to become the consent holder once the road was vested and therefore suggest that the current Condition 41 is deleted and replaced as follows:

Delete Condition 41 in its entirety:

~~41. THAT the consent holder shall submit confirmation from the Bay of Plenty Regional Council, that all necessary consents in relation to the subdivision have been granted. In the case where the Western Bay of Plenty District Council shall become the consent holder, any conditions of the consent will be subject to the approval of Council's **Chief Executive Officer or duly Authorised Officer** (This approval shall not be withheld unless the consent conditions are considered to be either unworkable or cost prohibitive in respect of future maintenance). That written confirmation shall be provided from the Bay of Plenty Regional Council that the works required by this condition have been completed to their satisfaction.~~

Replace as follows:

41. THAT where any consent from Bay of Plenty Regional Council is obtained where WBOPDC shall become the consent holder (i.e. vested asset) , any conditions of the consent will be subject to the approval of Council's **Chief Executive Officer or duly Authorised Officer** prior to accepting the asset for vesting at the time of Sec 224 approval (This approval shall not be withheld unless the consent

conditions are considered to be either unworkable or cost prohibitive in respect of future maintenance).

- 8.17 Condition (64) requires the proposed rights of way EA, EB, EC, ED and EF as identified on the scheme plan to be constructed in accordance with the Development Code. In terms of proposed rights of way EA, EB, EC, ED this is appropriate, however proposed privateway EF only serves one lot (Lot 17). Under the District Plan where only one allotment is served there is no upgrading required and accordingly reference to EF should be deleted from this condition. We also note that privateway EF is within the QEII features and no works to disturb any additional vegetation are permitted per the agreement with QEII which would be required should this condition remain as originally proposed. Accordingly, I consider the condition should be amended as follows:

64 THAT the proposed Privateways EA, EB, EC, ED ~~and EF~~ shall be constructed in accordance with Council's Standard Specification Drawing No's W439 and W440. The type of surface to be provided (sealed or unsealed) shall be assessed at the engineering documents stage and shall comply with Council Minden Lifestyle rules and shall comply with the District Plan Rule in respect to neighbours consent to unsealed surfaces.

- 8.18 Furthermore, I note that whilst there are a number of walkways proposed either to be vested or covered by easement in gross, there are currently no specific conditions relating to the construction standard of these walkways. In my view it is important to clarify this through a condition of consent so that all parties are clear on the standard should approval to the consent be granted. The applicant proposes that the walkways will have a minimum formed width of 1.5m, finished to a compacted all weather standard. Fencing of the walkway easement/lot boundary is proposed to be a minimum of a 5 wire standard rural fence. Where walkways co align with a privateway, it is proposed that only the side of the walkway opposite to the carriageway would be fenced. As such, I consider that an additional condition is required as follows:

THAT the proposed walkways to be vested and/or covered by easement in gross are constructed to a minimum width of 1.5m and finished to a compacted all weather surface. Fencing of the walkway corridor shall include a minimum 5 wire rural fence, except that where a walkway co-aligns with a privateway, fencing shall be limited to the side of walkway opposite the privateway carriageway only.

- 8.19 I have appended an updated suite of conditions incorporating the above changes at Appendix D of my evidence.

9. CONCLUSIONS

- 9.1 In this evidence I have provided my opinion in relation to the Section 104 assessment requirements of the Act. I have relied on the specialist reports prepared by Mr Richard Hart, Mr Bruce Harrison and relevant engineering reports (i.e. geotechnical, OSET, contaminated soils) to conclude that overall any potential adverse effects will be no more than minor. In addition, I have concluded that potential effects generated by the proposal can adequately be mitigated.
- 9.2 I have concluded the proposal is consistent with the objective and policy framework of the relevant planning instruments.
- 9.3 I consider that the proposal is able to meet both limbs of Section 104D of the Act (“the gateway test”).
- 9.4 As set out in Section 7 above, it is my opinion that the Proposal is consistent with Part 2 of the Act.
- 9.5 Overall, it is my opinion that granting consent to the proposal is able to meet the sustainable management purpose of the Act.

S.M. Crossan

3 April 2019

DRAFT
Areas and measurements subject to Chief Surveyors approval

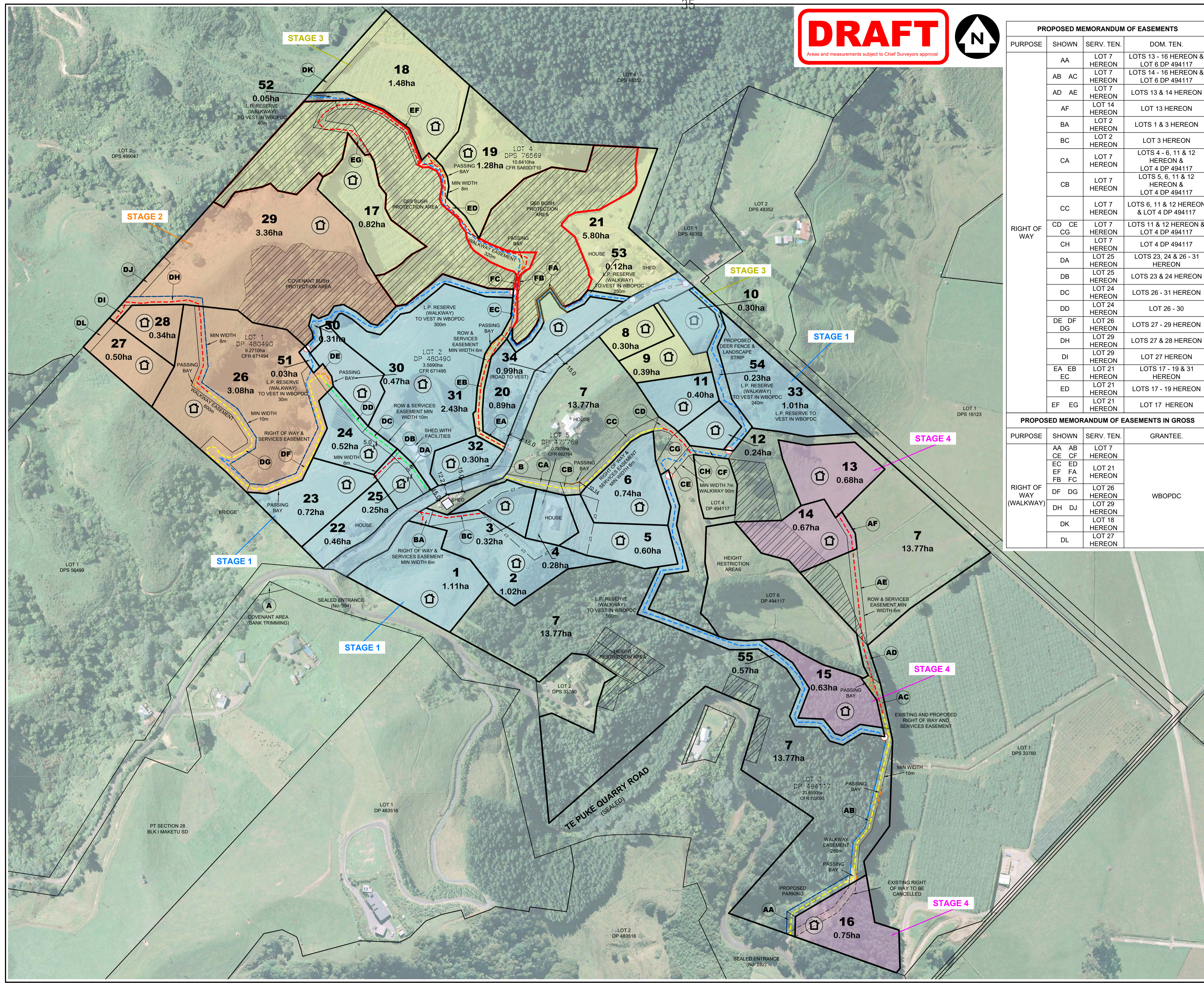
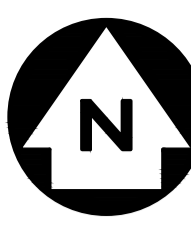

PROPOSED MEMORANDUM OF EASEMENTS			
PURPOSE	SHOWN	SERV. TEN.	DOM. TEN.
	AA	LOT 7 HEREON	LOTS 13 - 16 HEREON & LOT 6 DP 494117
	AB AC	LOT 7 HEREON	LOTS 14 - 16 HEREON & LOT 6 DP 494117
	AD AE	LOT 7 HEREON	LOTS 13 & 14 HEREON
	AF	LOT 14 HEREON	LOT 13 HEREON
	BA	LOT 2 HEREON	LOTS 1 & 3 HEREON
	BC	LOT 2 HEREON	LOT 3 HEREON
	CA	LOT 7 HEREON	LOTS 4 - 6, 11 & 12 HEREON & LOT 4 DP 494117
	CB	LOT 7 HEREON	LOTS 5, 6, 11 & 12 HEREON & LOT 4 DP 494117
	CC	LOT 7 HEREON	LOTS 6, 11 & 12 HEREON & LOT 4 DP 494117
RIGHT OF WAY	CD CE	LOT 7 HEREON	LOTS 11 & 12 HEREON & LOT 4 DP 494117
	CG	LOT 7 HEREON	LOT 4 DP 494117
	CH	LOT 7 HEREON	LOT 4 DP 494117
	DA	LOT 25 HEREON	LOTS 23, 24 & 26 - 31 HEREON
	DB	LOT 25 HEREON	LOTS 23 & 24 HEREON
	DC	LOT 24 HEREON	LOTS 26 - 31 HEREON
	DD	LOT 24 HEREON	LOT 26 - 30
	DE DF	LOT 26 HEREON	LOTS 27 - 29 HEREON
DG	LOT 29 HEREON	LOTS 27 & 28 HEREON	
DH	LOT 29 HEREON	LOT 27 HEREON	
DI	LOT 21 HEREON	LOTS 17 - 19 & 31 HEREON	
EA EB	LOT 21 HEREON	LOTS 17 - 19 & 31 HEREON	
EC	LOT 21 HEREON	LOTS 17 - 19 HEREON	
ED	LOT 21 HEREON	LOTS 17 - 19 HEREON	
EF EG	LOT 21 HEREON	LOT 17 HEREON	

PROPOSED MEMORANDUM OF EASEMENTS IN GROSS			
PURPOSE	SHOWN	SERV. TEN.	GRANTEE.
RIGHT OF WAY (WALKWAY)	AA AB	LOT 7 HEREON	WBOPDC
	CE CF	LOT 21 HEREON	
	EC ED	LOT 21 HEREON	
	EF FA	LOT 21 HEREON	
	FB FC	LOT 21 HEREON	
	DF DG	LOT 26 HEREON	
	DH DJ	LOT 29 HEREON	
	DK	LOT 18 HEREON	
DL	LOT 27 HEREON		

DRAWN: MJH	DESIGNED: -		
CHECKED: -	SURVEYED BY: -		
OFFICE OF ORIGIN - TE PUKE Ph 07 573 7717			
No.	Date	By	Issue/Revision
A	05.07.18	MJH	DRAFT
B	16.10.18	MJH	ISSUED
C	06.12.18	MJH	ISSUED
D	01.04.19	MJH	ISSUED

- NOTES/KEY:**
- BOUNDARIES HAVE BEEN OBTAINED FROM LINZ DATA SERVICE AND HAVE NOT BEEN VERIFIED.
 - AREAS AND MEASUREMENTS ARE APPROXIMATE AND SUBJECT TO SURVEY.
 - APPURTENANT OR PROPOSED EASEMENTS IN RELATION TO THE SUBJECT LAND MAY NOT HAVE BEEN SHOWN IF NOT REQUIRED FOR COMPLIANCE OF THIS PROPOSAL.
 - DATUM
 - HORIZONTAL DATUM: BAY OF PLENTY 2000
 - DENOTES POSSIBLE HOUSE SITE.
 - 1 - 3 LOT PRIVATE WAY
 - 4 - 6 LOT PRIVATE WAY
 - 7+ LOT PRIVATE WAY
 - WALKWAYS (GREEN LANES)
 - UNLESS OTHERWISE SHOWN, L.P. RESERVES (WALKWAY) ARE 7.0m WIDE
 - PROPOSED PASSING BAY LOCATIONS
 - EXISTING QEII BOUNDARY
 - EXISTING RESTRICTED AREAS
 - STAGING

STAGE 1	
STAGE 2	
STAGE 3	
STAGE 4	

(A) (B) COVENANT AREAS (SIGHT DISTANCES)

SERVICES NOTE
WHERE EXISTING SERVICES ARE SHOWN, THEY ARE INDICATIVE ONLY AND MAY NOT INCLUDE ALL SITE SERVICES. STRATUM CONSULTANTS LTD DOES NOT WARRANT THAT ALL, OR INDEED ANY SERVICES ARE SHOWN. IT IS THE CONTRACTORS RESPONSIBILITY TO LOCATE AND PROTECT ALL EXISTING SERVICES PRIOR TO AND FOR THE DURATION OF THE CONTRACT WORKS.

**394 TE PUKE QUARRY ROAD
TE PUKE QUARRY ROAD
TE PUKE**

**PROPOSED SUBDIVISION OF
LOT 4 DPS 76569, LOT 5 DP 477769,
LOTS 1 & 2 DP 480490 AND
LOT 3 DP 494117**

SCHEME PLAN



SCALE: 1:2000 ORIGINAL DWG. SIZE A1
DRAWING No. 415542-T-P-D002 SHEET No. 03 ISSUE D



Fenton McFadden

L A W Y E R S

Te Puke • Papamoa

- **TE PUKE**
Oxford Street
PO Box 36, Te Puke 3153
Tel: 07 573-8681
Fax: 07 573-6745
Email: admin@fentonlaw.co.nz
- **PAPAMOA**
558 Papamoa Beach Road
Papamoa
PO Box 36, Te Puke 3153
Tel: 07 542-1200
Fax: 07 542-1299
Email: papamoa@fentonlaw.co.nz

DX HA42510

20 March 2019

The Trustees
John & Jenny Dohnt Family Trust
PO Box 452
TE PUKE 3153

J L & J M Dohnt Partnership
PO Box 452
TE PUKE 3153

SUBDIVISION AT TE PUKE QUARRY ROAD, TE PUKE

We have reviewed the documentation relating to the right of way over your property from Te Puke Quarry Road and summarise the position as follows:

1. The Right of Way easement was originally granted in favour of Lot 1 DPS 8958 as an alternative access to that block. It appears it was intentionally *not* created in favour of Lot 2 DPS 8958 (which had existing legal access).
2. When Lot 2 DPS 8958 was subdivided, Lot 1 DPS 48352 was amalgamated with Lot 4 DPS 48253 (previously Lot 1 DPS 8958), and a right of way in favour of Lot 2 48253 (previously Lot 2 DPS 8958) was *not* created at that time either (although there were new rights of way in respect of other areas created at that time).
3. It was only as a result of Lot 3 DPS 48253 (which contains the pump shed) previously forming part of Lot 1 DPS 8958 that the benefit of the easement came down on to the amalgamated title for Lot 2-3 DPS48352, and it is noted that on the Record of Title that it only affects Lot 3 DPS 18352.

In our view, it is arguable that the owner of (now) Lot 2-3 DPS 48352 does not have a legal right to use the right of way other than in respect of Lot 3 DPS 18352.

Yours faithfully
FENTON McFADDEN

Anna McFadden
Partner
Email: anna@fentonlaw.co.nz

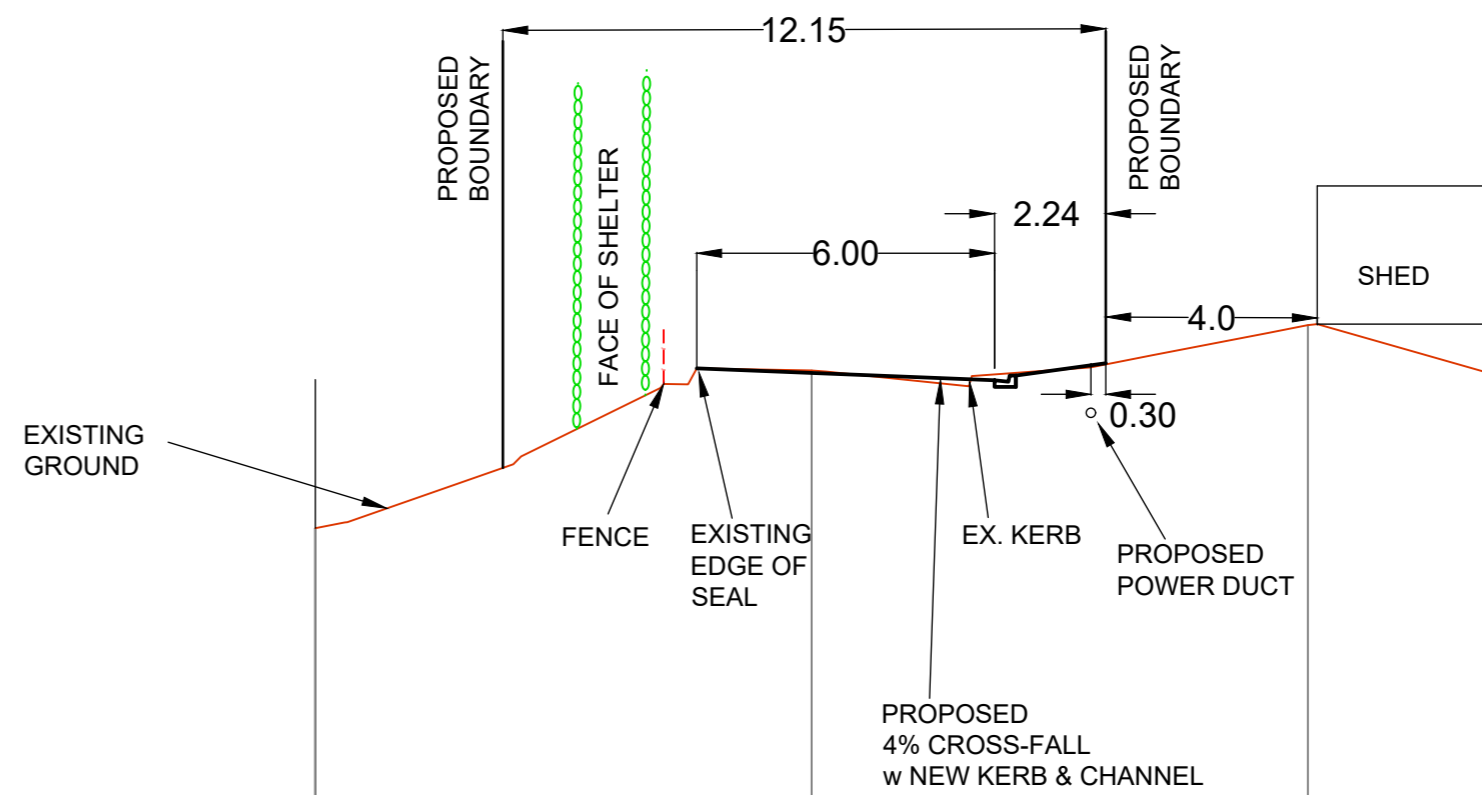
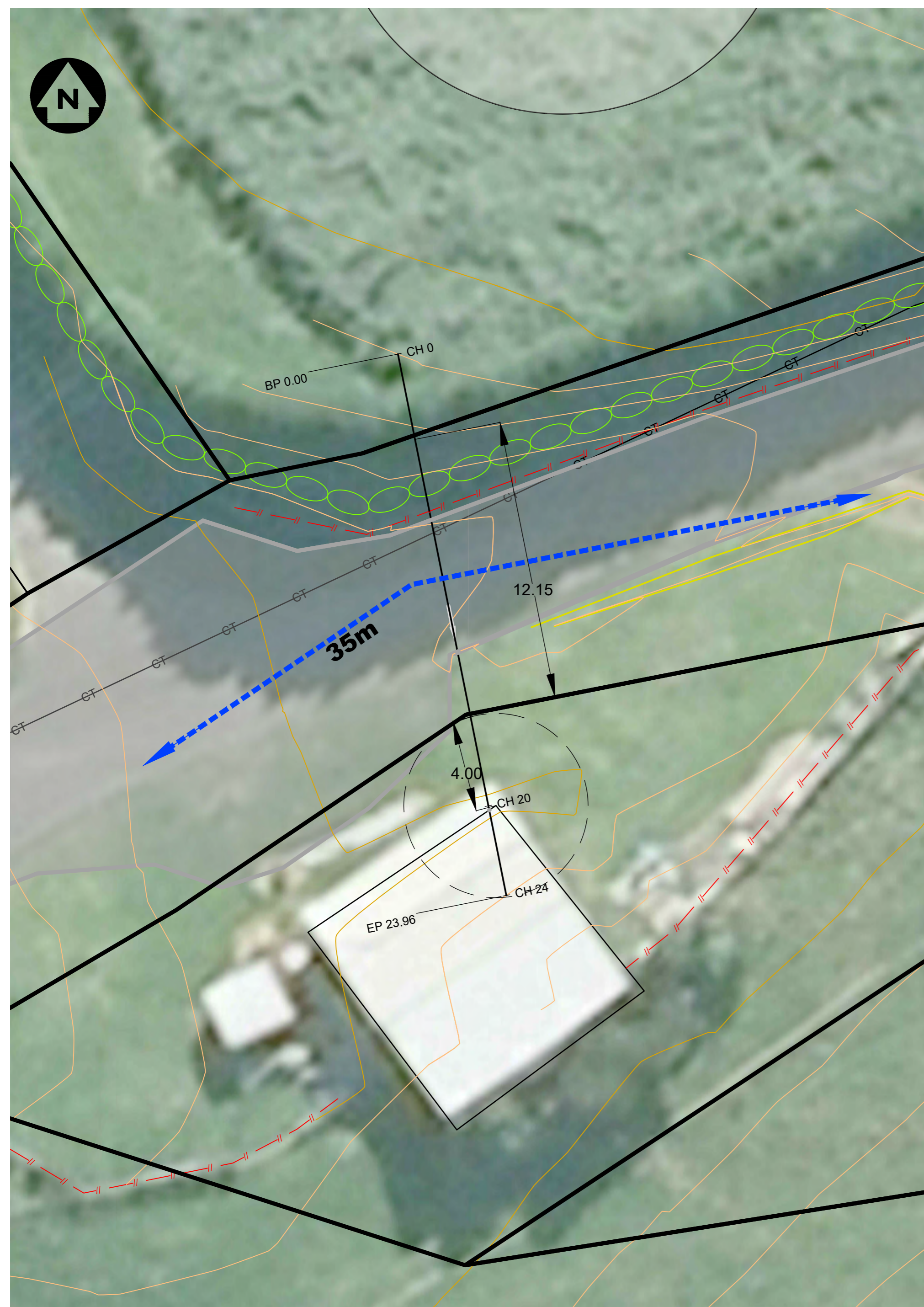

VERT EXAG 1:2
Datum 85.000

DESIGN LEVELS	92.089	92.547
EXISTING LEVELS	92.089	92.547
CHAINAGE	10.000	20.000

CROSS SECTION - SHED INTERSECTION AREA

DRAWN:	DRU	DESIGNED:	-
CHECKED:	-	SURVEYED BY:	DRU
OFFICE OF ORIGIN - TE PUKE Ph 07 573 7717			
No.	Date	By	Issue/Revision
A	03.04.19	MJH	DRAFT
B	-	-	-
C	-	-	-

NOTES/KEY:

- BOUNDARIES HAVE BEEN OBTAINED FROM LINZ DATA SERVICE AND HAVE NOT BEEN VERIFIED.
- AREAS AND MEASUREMENTS ARE APPROXIMATE AND SUBJECT TO SURVEY.
- APPURTENANT OR PROPOSED EASEMENTS IN RELATION TO THE SUBJECT LAND MAY NOT HAVE BEEN SHOWN IF NOT REQUIRED FOR COMPLIANCE OF THIS PROPOSAL.
- CONTOURS HAVE BEEN OBTAINED FROM BOPLAS LIMITED AND HAVE NOT BEEN VERIFIED ON GROUND.
- DATUM
 - HORIZONTAL DATUM: BAY OF PLENTY 2000
 - VERTICAL DATUM: MOTURIKI 1953

- DENOTES POSSIBLE HOUSE SITE.
- 1 - 3 LOT PRIVATE WAY
- 4 - 6 LOT PRIVATE WAY
- 7+ LOT PRIVATE WAY
- WALKWAYS

SERVICES NOTE

WHERE EXISTING SERVICES ARE SHOWN, THEY ARE INDICATIVE ONLY AND MAY NOT INCLUDE ALL SITE SERVICES. STRATUM CONSULTANTS LTD DOES NOT WARRANT THAT ALL OR INDEED ANY SERVICES ARE SHOWN. IT IS THE CONTRACTORS RESPONSIBILITY TO LOCATE AND PROTECT ALL EXISTING SERVICES PRIOR TO AND FOR THE DURATION OF THE CONTRACT WORKS.

394 TE PUKE QUARRY ROAD
TE PUKE QUARRY ROAD
TE PUKE

PROPOSED SUBDIVISION OF LOT 4 DPS 76569,
LOT 5 DP 477769, LOTS 1 & 2 DP 480490 AND
LOT 3 DP 494117

SHED INTERSECTION AREA



Planners | Engineers | Surveyors

SCALE:	1 : 150	ORIGINAL DWG. SIZE:	A2
DRAWING No.	415542-T-S-D001	SHEET No.	06
		ISSUE	A

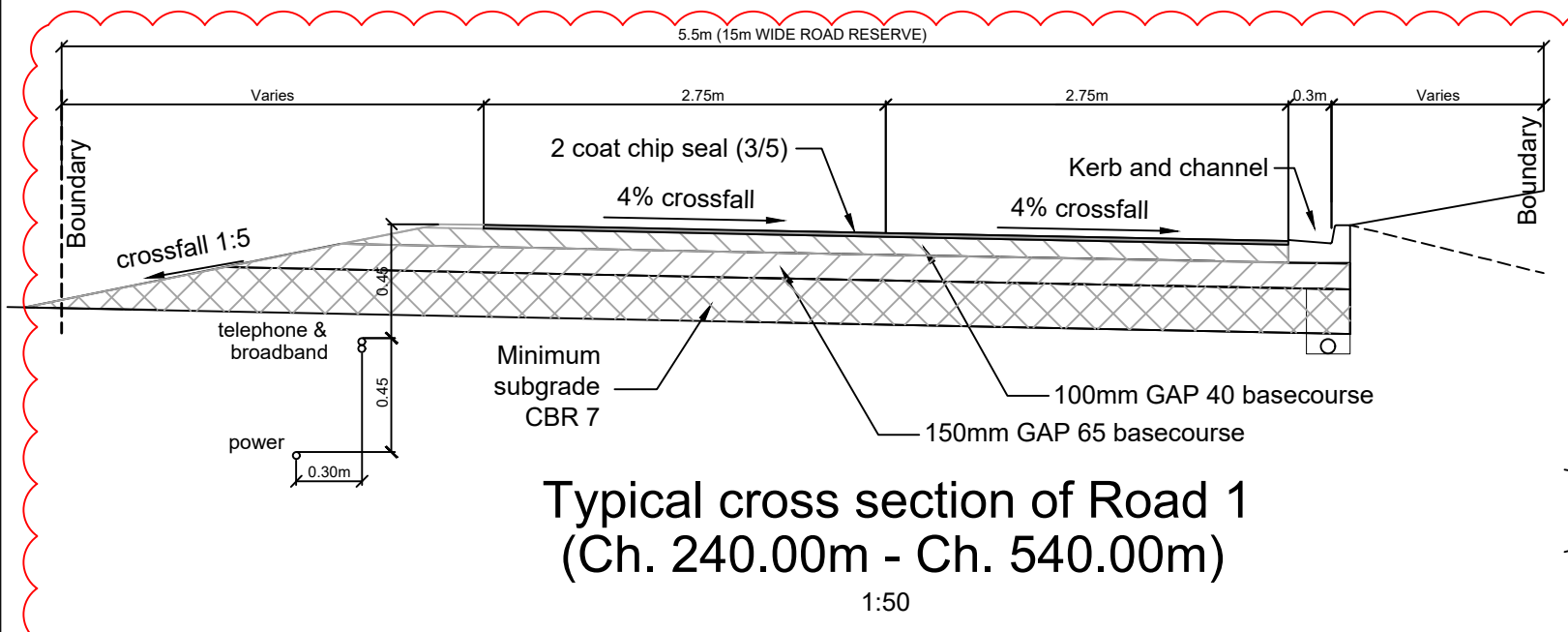

Typical cross section of Road 1
(Ch. 240.00m - Ch. 540.00m)

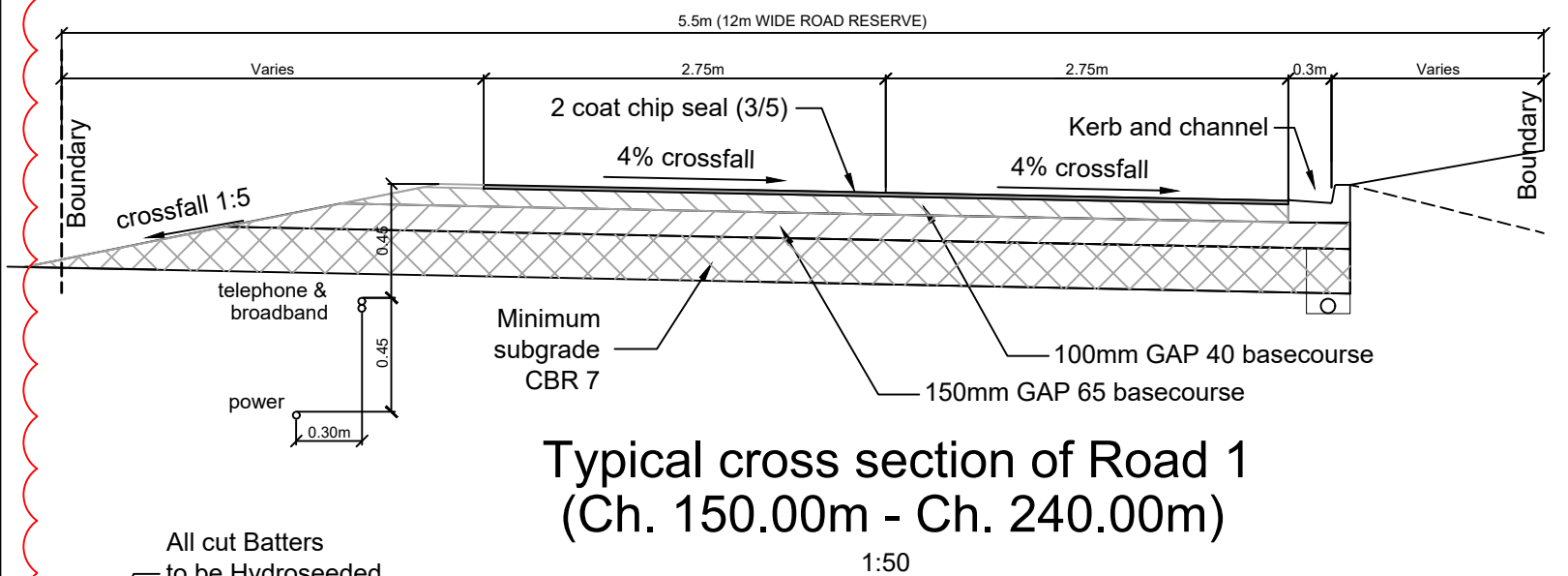

Typical cross section of Road 1
(Ch. 150.00m - Ch. 240.00m)

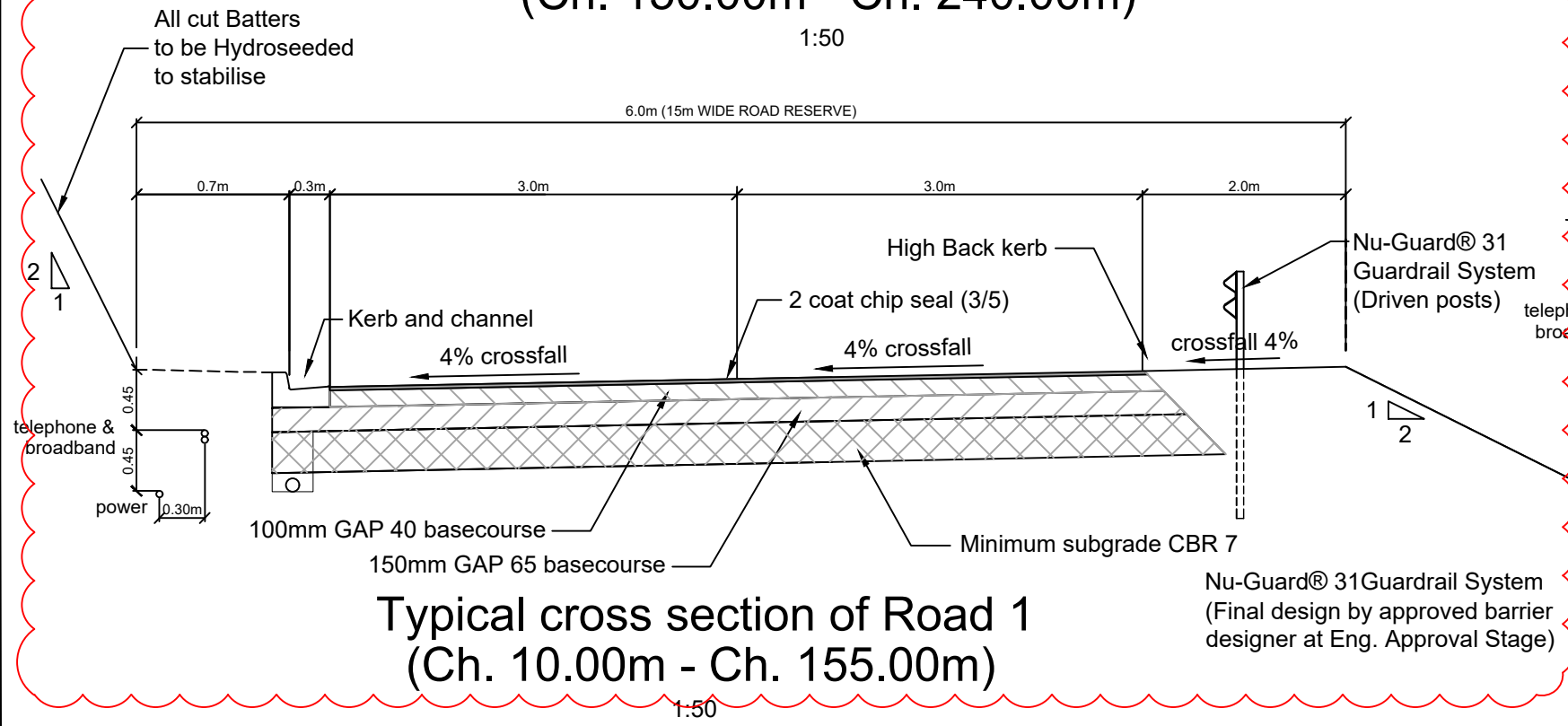

Typical cross section of Road 1
(Ch. 10.00m - Ch. 155.00m)

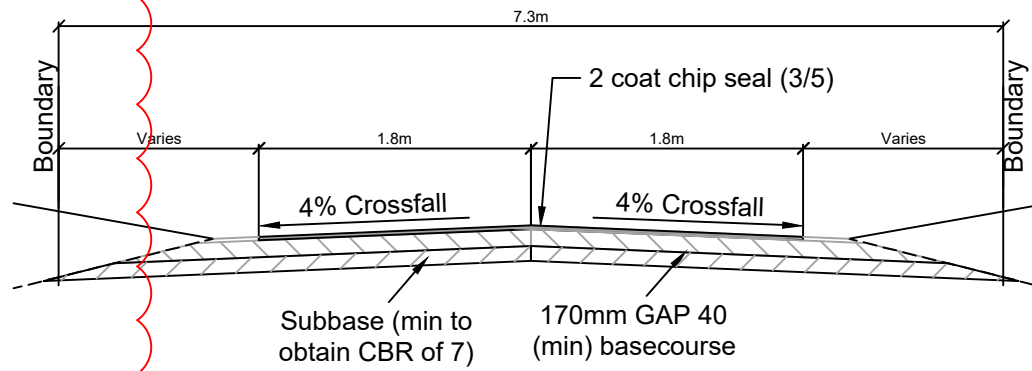

Typical cross section of ROW

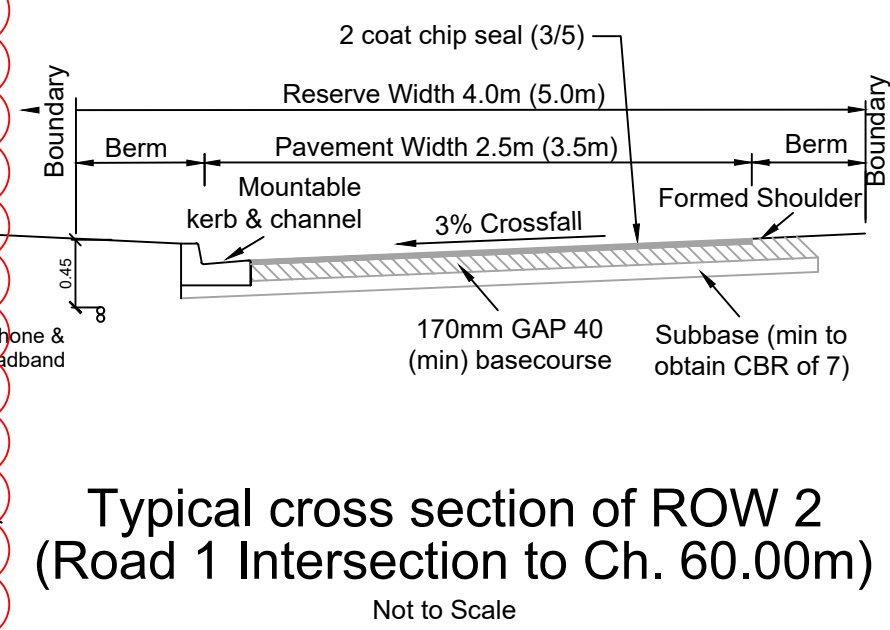

Typical cross section of ROW 2
(Road 1 Intersection to Ch. 60.00m)

DRAWN: ADP	DESIGNED: ADP		
CHECKED: TJH	SURVEYED BY: DU		
OFFICE OF ORIGIN - TAURANGA Ph 07 571 4500			
No.	Date	By	Issue/Revision
A	13.06.18	ADP	ISSUED FOR DISCUSSION
B	23-07-18	ADP	ISSUED FOR RESOURCE CONSENT
C	26-10-18	ADP	NOTES ADDED
D	12-11-18	ADP	NOTE ADDED
E	11-12-18	ADP	EMBANKMENT ADDED
F	02-04-19	ADP	ADDITIONAL CROSS SECTION ADDED

- ALL WORKS TO COMPLY WITH WESTERN BAY OF PLENTY COUNCIL STANDARDS.
- ALL WORKS TO BE CARRIED OUT BY APPROVED CONTRACTOR.
- ALL PIPES UNDER CARRIGEWAYS AND VEHICLE CROSSINGS TO BE BACKFILLED WITH COMPACTED HARDFILL.
- CONTRACTOR TO SEARCH, LOCATE, PROTECT AND MAINTAIN ALL EXISTING SERVICES.
- CONTRACTOR TO ARRANGE FOR TRAFFIC MANAGEMENT AND ALL NECESSARY PERMITS TO WORK WITHIN THE ROAD AND OR RESERVE.

- KEY:**
- NEW STORMWATER PIPE
 - RETAINING WALL
 - OVERLANDFLOW

ROAD

2 COAT CHIP SEAL
ON 100mm GAP40 ON 150mm GAP65
CONSTRUCTION DEPTH
BASED ON CBR ≥ 7%

ROW's

2 COAT CHIP SEAL
ON 170mm GAP40

SERVICES NOTE

WHERE EXISTING SERVICES ARE SHOWN, THEY ARE INDICATIVE ONLY AND MAY NOT INCLUDE ALL SITE SERVICES. STRATUM CONSULTANTS LTD DOES NOT WARRANT THAT ALL, OR INDEED ANY SERVICES ARE SHOWN. IT IS THE CONTRACTORS RESPONSIBILITY TO LOCATE AND PROTECT ALL EXISTING SERVICES PRIOR TO AND FOR THE DURATION OF THE CONTRACT WORKS.

DOHNT FAMILY TRUST
TE PUKE QUARRY ROAD
TE PUKE

PROPOSED SUBDIVISION OF
LOT 3 DP 494117
ROAD DETAIL CROSS SECTIONS



Planners | Engineers | Surveyors

SCALE: 1:500	ORIGINAL DWG. SIZE A3
DRAWING No. 415542-M-E-D002	SHEET No. 13
	ISSUE F

Shae Crossan - Proposed Conditions

ALL STAGES:

General

1. *THAT the activity be carried out in accordance with the application submitted (subject to any changes required through compliance with the following conditions) including:*
 - a) *Stratum Consultants Ltd Subdivision Consent Application Ref. 415542-P-C001, dated 16 August 2018.*
 - b) *Stratum Consultants Ltd Subdivision Scheme Plan Ref. 415542-T-P-C001, Sheet 03, Issue C, dated 16 August 2018*
 - c) *Stratum Consultants Ltd Geotechnical Assessment Report Ref. 415542-M-E--C001, dated 27 July 2018.*
 - d) *Stratum Consultants Ltd Preliminary Site Investigation Ref. 415542-M-P-C001, dated 11 April 2018*
 - e) *Stratum Consultants Ltd On-Site Effluent Treatment Feasibility Report Ref. 415542-M-P-C001, dated 18 May 2018.*
 - f) *Richard Hart Ltd, Assessment of Landscape and Visual Effects (Lots 23-29), unreferenced and dated 31 July 2018*
 - g) *Harrison Transportation Concept Stage Road Safety Audit REF. 275TA v1, dated August 2017*
 - h) *Stratum Consultants Ltd section 92 response Ref. 415542-M-P-C001, dated 28 October 2018*
 - i) *Stratum Consultants Ltd Stability Assessment of Proposed Road Embankment, Ref. 415542-M-E--C001, dated 11 December 2018.*
2. *Any staging of subdivision consent by way of s223 / 224 certificates issued on separate survey for this subdivision is appropriate subject to that staging complying with all relevant conditions as listed for that stage within this subdivision consent.*
3. *All easements required for underground services and rights of way serving lots within the subdivision shall be duly granted or reserved.*
4. *All costs associated with the conditions of this consent shall be met by the consent holder*

Engineering

5. *THAT a Category 1 Geo-professional suitably experienced to the satisfaction of the Chief Executive Officer or duly authorised officer; shall supervise all earthworks and shall prepare a geotechnical completion report which describes the extent of the earthworks, the extent of inspection, provide copies of test data, including settlement monitoring, test bores test / compaction results achieved, test locations and a statement of professional opinion in respect to the following:*
 - a) *That the earthworks construction has been undertaken in accordance with the recommendations of the Stratum Consultants reports dated 27 July and 11 December 2018 in respect to the construction of the proposed road including the embankments and the construction of the Privateway formations.*

- b) *Any retaining structures required to support the proposed Roads, Privateways or to support the proposed building platforms.*
 - c) *That where earthworks are undertaken to provide a building platform on an allotment, they shall be suitable for the erection thereon of residential buildings providing ultimate bearing capacities greater than 300 kPa in accordance with NZS 3604 and/or that certification for each residential Lot is provided in accordance with NZS 4404 (Appendix B). At the discretion of the Chief Executive Officer or duly authorized officer, consent notices may be registered on the Lots where specific foundation type such as piles are required because of UBC is less than 300 kpa.*
 - d) *Allotments which are subject to building restriction lines which will shall be shown on the Land Transfer Plan.*
 - e) *Recommendations in respect to the location of soak holes to embankments.*
 - f) *Where a consent notices pursuant to Section 221 of the Resource Management Act 1991 is required, the notice shall state that all future development be in accordance with the relevant geotechnical report (or subsequent approved report) and include clear reference to the report including date, author, reference and revision numbers as applicable.*
6. *THAT an accurate Council issued RAPID (Rural Address Property IDentification) plate be displayed at the vehicle entrance for each new Lot created in accordance with **Western Bay of Plenty District Council's Rural Property Numbering Bylaw 2005**. This condition shall be satisfied prior to the application for 224c certification from Council.*
 7. *THAT design and construction shall be carried out to ensure that stormwater overland flow paths are provided clear of the buildable area of each Lot and to take into account the runoff from areas of road, including adjacent catchment where relevant.*
 8. *THAT electricity reticulation shall be installed to serve the development with the capacity and ability to later provide all proposed Rural **lots with individual connections (lead in's)**. Letters are required from the electricity authorities confirming that this condition has been met to their satisfaction. In addition, ducting shall be provided for fibre reticulation should this become available.*
 9. ***THAT the consent holder's representative shall submit to the Chief Executive Officer or duly Authorised Officer for approval, with the appropriate engineering inspection fee; construction drawings, specifications, calculations and project cost estimate; covering all sections of work which it is proposed to be built in accordance with Council's Development Code and vest in Council. Construction shall not commence until written approval of the plans and specification has been provided by Council.***
 10. ***THAT the consent holder's representative shall submit to the Chief Executive Officer or duly Authorised Officer, all quality assurance and testing records that are required in accordance with Council's Development Code, including sealing records.***
 11. *THAT as-built information and drawings shall be provided for all vested assets and service connections*

12. *THAT a 5 percent maintenance bond calculated from the approved asset schedule (Cert 1c) shall be paid in respect to the additional Council assets created by this subdivision, in accordance with the requirements of Council's Development Code.*
13. *THAT at the end of the maintenance period, all maintenance items are required to be certified as complete including that the berms have been mown, carriageways swept and catchpits cleaned by the consent holder's representative.*

STAGE 1:

Financial Contributions

14. *THAT the following financial contributions be paid in respect of the subdivision:*

<i>a) Rural Roding (Te Puke Ward)</i>	<i>13 x \$8763</i>	<i>\$113,919(+ GST)</i>
<i>b) District Wide Roding</i>	<i>13 x \$1385</i>	<i>\$18,005(+ GST)</i>
<i>c) Recreation and Leisure</i>	<i>13 x \$7423</i>	<i>\$96,499(+ GST)</i>
<i>d) Ecological</i>	<i>13 x 501</i>	<i>\$6513(+GST)</i>

15. *THAT with regard to Condition (12), the financial contributions calculated in accordance with the provisions of the Operative District Plan, shall be paid within full within two years of the date of commencement of the consent provided that:*
- a) Any financial contribution which is not paid in full within two years from the date of commencement of the consent shall be adjusted so that the amount of the financial contribution required by the resource consent shall be the amount calculated in accordance with the relevant formulae using the updated inputs to those formulae as set out in Council's Annual Plan current at the date of payment.*
- b) Any financial contributions not paid within two years from the date of the commencement of the consent shall be (where applicable) paid prior to the issue of a Building Consent under the Building Act 2004, subject to the adjustments referred to in sub-paragraph (a) herein.*

Easements, Covenants and Vesting

16. *The consent holder shall register an easement in gross in favour of the Council over Lot 7 within the area shown as Area 'CE', 'CF' and 'CG', as shown on the plan of subdivision.*

The easements in gross shall be shown on the survey plan prior to certification pursuant to Section 223 of the Resource Management Act 1991 and shall be shown as a "Right of Way" and be registered on the survey plan under a "Memorandum of Easements in Gross."

17. *THAT a land covenant be registered over Pt Sec 28 SO 7648 BLK 1 Maketu SD (Identifier 28A/526) to include Covenant Area 'A' shown on the scheme plan. The land covenant shall be submitted to the Chief Executive Officer, or duly authorised officer, for approval and be worded to ensure that:*
- a) The owner of Pt Sec 28 SO 7648 BLK 1 Maketu SD cannot undertake activities within the covenanted area that would interfere with the intersection sight distances shown on Stratum Consultants Ltd Te Puke Quarry Road and Road 1 Intersection*

Sight Lines Plan Dwg. No. 415542-M-E-D002, Sheet 03A, Issue B, dated 23 July 2018; and

- b) *That the Council is able to maintain the covenanted area as required to ensure intersection sight distances are maintained.*
18. ***THAT a land covenant be registered over Lot 32 to include Covenant Area 'B' shown on the scheme plan. The land covenant shall be submitted to the Chief Executive Officer, or duly authorised officer, for approval and be worded to ensure that:***
- a) *The owner of Lot 32 cannot undertake activities within the covenanted area that would interfere with the sight distances shown on Stratum Consultants Ltd Road 1 Layout Plan Dwg. No. 415542-M-E-D002, Sheet 04, Issue C, dated 26 October 2018; and*
- b) *That the Council is able to maintain the covenanted area as required to ensure intersection sight distances are maintained.*
19. *The Lot 33 shall be vested in the Council as Recreation Reserve and be shown on the survey prior to certification pursuant to section 223 of the Resource Management Act 1991.*
20. *The Lot 34 shall be vested in the Council as Road and be shown on the survey prior to certification pursuant to section 223 of the Resource Management Act 1991.*
21. *The Lots 50, 51, 53, 54 and 55 shall be vested in the Council as Local Purpose (Access) Reserve and be shown on the survey prior to certification pursuant to section 223 of the Resource Management Act 1991 shown on the scheme plan as.*

Consent Notices

22. *Pursuant to Section 221 of the Resource Management Act 1991, a consent notice shall be registered on the Certificate of Titles for Lots 23, 24 and 25 advising the owners and subsequent owners thereof, of the following requirement to be complied with on a continuing basis*

For Lots 23, 24 and 25:

- a) *All buildings and rain tanks shall be designed to have a light reflectance value (LRV) that does not exceed the following:*
- i) *40% LRV and limited to Groups A & B of BS 5252*
- b) *A landscape plan shall be submitted at building consent stage for approval in general accordance with the Richard Hart Ltd, Assessment of Landscape and Visual Effects (Lots 23-29), unreferenced and dated 31 July 2018 and include trees and massed plantings that integrate the house sites into the landscape.*

Landscaping shall be implemented in the next available planting season and maintained in perpetuity in accordance with the approved plan.

For Lot 25 only:

- c) *Buildings on this lot shall not exceed a height of 6 metres.*

23. Pursuant to Section 221 of the Resource Management Act 1991, a consent notice shall be registered on the Certificate of Titles for Lots 31 and 32 advising the owners and subsequent owners thereof, of the following requirement to be complied with on a continuing basis

This lot includes land covered under Regulation 5(7) of the National Environmental Standard for Assessing and Managing Contaminants in Soil to Protect Human Health (NESCS). Disturbance of soil on the lot shall not occur unless:

- a) A preliminary site investigation or detailed site investigation is submitted to the Council to confirm soil contamination levels do not exceed NESCS levels; or*
 - b) A consent for soil disturbance has been issued pursuant to the NESCS by the Council.*
24. Pursuant to Section 221 of the Resource Management Act 1991, a consent notice shall be registered on the Certificate of Titles for Lots 1 – 6, 11, 12, 20, 22 - 25 and 30 – 32 advising the owners and subsequent owners thereof, of the following requirement to be complied with on a continuing basis:
- a) That any earthworks on the lot and the design and construction of any building or structure requiring a building consent in accordance with the Building Act 2004 shall comply with the recommendations in the Stratum Consultants Ltd Geotechnical Assessment Report Ref. 415542-M-E--C001, dated 27 July 2018;*
 - b) The design and construction of any building or structure requiring a building consent in accordance with the Building Act 2004 shall demonstrate that firefighting capability is provided in accordance with the New Zealand Fire Service Firefighting Water Supplies Code of Practice SNZ PAS 4509:2008 (or any relevant superseding code).*

25. Pursuant to Section 221 of the Resource Management Act 1991, a consent notice shall be registered on the Certificate of Titles for Lots 5, 6, 7, 11, 12, 20, 30 and 31 advising the owners and subsequent owners thereof, of the following requirement to be complied with on a continuing basis

The owners of this lot are required to meet the full cost of any fencing along the common boundary between the lot and the adjoining land used for reserve purposes.

Engineering

26. **THAT street signs shall be erected at approved locations naming all proposed new roads in accordance with Council's Development Code. The proposed street names will also require formal pre-approval from Council.**
27. *THAT the proposed intersection of Lot 34 to Te Puke Quarry Road shall be constructed to a design to be submitted to the Chief Executive Officer, or duly authorised officer, for approval including construction drawings and specifications prior to commencing any work on site.*
28. *THAT street lighting shall be provided at the proposed intersection of Lot 34 to Te Puke Quarry Road or at any other location recommended in the design safety audit in accordance with AS/NZS 1158 2005 Road Lighting, as modified by NZTA specification M30 (LED luminaires) and in accordance with Auckland Transport's approved Streetlight*

List. The design shall be certified to comply with the above requirements by a suitably qualified person to the satisfaction of the Chief Executive Officer or duly authorised officer prior to construction. Confirmation is also required from the power supply authority that the street lights are operational.

29. THAT a minimum 15m wide road reserve corridor (except the 12m wide section identified as shown on the Stratum Consultants Ltd Plan 415542-T-S-D001, Sheet 06, Issue A) shall be vested over the proposed road alignment but the width shall also include all existing / proposed cut and fill batters and any sight distance splays in **accordance along the road alignment with Council's Development Code. This may require the proposed road reserve boundary to be moved to accommodate the above criteria.**
30. **The design of the proposed Road Lot 34 shall comply with Council's District Plan and Development Code requirements including Council's standard drawing number W417, except as follows:**
 - a) Carriageway widths shall be 6.0m wide and 5.5m wide.
 - b) A road with a centre line and single cross fall shall be provided
31. That a guard rail design be provided with the engineering documents in accordance with the Development Code requirements.
32. THAT a sealed car parking area be constructed within the road reserve near the proposed cul-de-sac head. The final location shall be determine at the engineering design stage. The depth of the pavement shall be designed for the potential traffic loadings.
33. That the road design shall be subject to a road design safety audit which shall review as a minimum the road geometry, sight distance requirements, K values for the vertical curves, guard rail design, pavement marking and speed advisory signage requirements.
34. THAT sealed vehicle entrances to serve all confined vehicle entrance locations, all the existing entrances served from Lot 34 and all the proposed privateways shall be constructed in accordance with Council's Standard Specification Drawing **No's W436 and W437 (Diagram C)**. The entrance shall be sized in accordance with Drawing number W437. A culvert shall be installed to convey stormwater and to protect the **Council road, alternatively at the developer's representative discretion and approved by Council**, the culvert can be substituted by a swale being constructed to the same contour as the existing table drain. Where the vehicle entrance adjoins a kerb and channelling a 1.2m deep Commercial apron shall be provided in accordance with drawing number W435 and W436.
35. That the existing vehicle crossing serving Lot 22 shall be relocated clear of the **proposed intersection Lot 34 in accordance with Council's standard drawing number W414**. The owner shall be advised 10 working days in advance of the proposed works **and those works shall be undertaken at the consent holder's expense.**
36. THAT all proposed or relocated vehicle entrance to be served from the proposed road Lot 34 shall be assessed in the design safety audit review.

37. *THAT a covenant be created over proposed Lot 32 and any other allotment to include the clear line of sight from the proposed vehicle entrances to serve Privateway EA by Transfer in accordance with the approved format.*
38. ***THAT the proposed Privateways identified on the scheme plan as 'BA', 'BC', 'CA', 'CB', 'CC', 'CD', 'CG', 'CH', 'DA', 'DB', 'DC', 'DD' and 'EA' shall be constructed in accordance with Council's Standard Specification Drawing No's W439 and W440 or subsequent design to be approved at Councils discretion at the time of engineering approval. The type of surface to be provided (sealed or unsealed) shall be assessed at the engineering documents stage and shall comply with Council Minden Lifestyle rules and shall comply with the District Plan Rule in respect to neighbour's consent to unsealed surfaces.***
39. *THAT design and construction shall be carried out to ensure that stormwater overland flow paths are provided clear of the buildable area of each Lot and to take into account the runoff from areas of road, including adjacent catchment where relevant.*
40. *THAT a storm water easement shall be created over any storm water pipe or overland flowpath resulting from the vested road on the affected allotments in favour of Council as dominant tenement and that this be shown on the survey plan.*
41. *THAT where any consent from Bay of Plenty Regional Council is obtained where WBOPDC shall become the consent holder (i.e. vested asset) , any conditions of the **consent will be subject to the approval of Council's Chief Executive Officer or duly Authorised Officer** prior to accepting the asset for vesting at the time of Sec 224 approval (This approval shall not be withheld unless the consent conditions are considered to be either unworkable or cost prohibitive in respect of future maintenance).*
42. *THAT consent to discharge stormwater on to private land shall be obtained from affected landowners prior to construction of discharge points from proposed road.*
43. *THAT a catchment analysis shall be undertaken and provided to Council to determine the size of the culvert required to serve the proposed Road Lot 34 and all culvert on the proposed privateways to cope with the appropriate design storm and be in **accordance with Council's Development Code.***
44. *THAT stormwater discharge from the proposed public road culvert onto the consent holder's land shall be legalised by Council's consent form "**Consent to Discharge of Stormwater onto Adjoining Land**", which shall be completed and signed by the consent holder and/or the owner of the land onto which the storm water is discharged.*
45. *THAT the work required by conditions (26) and (44) shall be supervised and certified as **complete in accordance with the conditions by the consent holder's representative** (refer Section 12.3.9a) to the satisfaction of the Chief Executive Officer or duly Authorised Officer, except that a Chartered Professional Engineer shall be responsible for providing **certification of earthworks and road pavement construction in accordance with Council's Development Code.***

STAGE 2:

Financial Contributions

46. THAT the following financial contributions be paid in respect of the subdivision:

a) Rural Roothing (Te Puke Ward)	4 x \$8763	\$35,052(+ GST)
b) District Wide Roothing	4 x \$1385	\$5,540(+ GST)
c) Recreation and Leisure	4 x \$7423	\$29,962(+ GST)
d) Ecological	4 x 501	\$2004(+GST)

47. THAT with regard to Condition (31), the financial contributions calculated in accordance with the provisions of the Operative District Plan, shall be paid within full within two years of the date of commencement of the consent provided that:

- a) Any financial contribution which is not paid in full within two years from the date of commencement of the consent shall be adjusted so that the amount of the financial contribution required by the resource consent shall be the amount calculated in accordance with the relevant formulae using the updated inputs to **those formulae as set out in Council's Annual Plan current at the date of payment.**
- b) Any financial contributions not paid within two years from the date of the commencement of the consent shall be (where applicable) paid prior to the issue of a Building Consent under the Building Act 2004, subject to the adjustments referred to in sub-paragraph (a) herein.

Easements

48. The consent holder shall register an easement in gross in favour of the Council over **Lot 7 within the area shown as Area 'CE', 'CF', 'CG' and 'CH'** as shown on the plan of subdivision.

The easements in gross shall be shown on the survey plan prior to certification pursuant to Section 223 of the Resource Management Act 1991 and shall be shown as a "Right of Way" and be registered on the survey plan under a "Memorandum of Easements in Gross."

Consent Notices

49. Pursuant to Section 221 of the Resource Management Act 1991, a consent notice shall be registered on the Certificate of Titles for Lots 26, 27, 28 and 29 advising the owners and subsequent owners thereof, of the following requirement to be complied with on a continuing basis

For Lots 26, 27, 28 and 29:

- a) All buildings and rain tanks shall be designed to have a light reflectance value (LRV) that does not exceed the following:
 - i) 40% LRV and limited to Groups A & B of BS 5252.
- b) A landscape plan shall be submitted at building consent stage for approval in general accordance with the Richard Hart Ltd, Assessment of Landscape and Visual Effects (Lots 23-29), unreferenced and dated 31 July 2018 and include trees and massed plantings that integrate the house sites into the landscape.

Landscaping shall be implemented in the next available planting season and maintained in perpetuity in accordance with the approved plan.

For Lots 27 and 28 only:

c) Buildings on this lot shall not exceed a height of 6 metres.

50. *Pursuant to Section 221 of the Resource Management Act 1991, a consent notice shall be registered on the Certificate of Titles for Lots 26, 27, 28 and 29 advising the owners and subsequent owners thereof, of the following requirement to be complied with on a continuing basis:*

a) The design and construction of any building or structure requiring a building consent in accordance with the Building Act 2004 shall comply with the recommendations Stratum Consultants Ltd Geotechnical Assessment Report Ref. 415542-M-E--C001, dated 27 July 2018.

b) The design and construction of any building or structure requiring a building consent in accordance with the Building Act 2004 shall demonstrate that firefighting capability is provided in accordance with the New Zealand Fire Service Firefighting Water Supplies Code of Practice SNZ PAS 4509:2008 (or any relevant superseding code).

51. *Pursuant to Section 221 of the Resource Management Act 1991, a consent notice shall be registered on the Certificate of Titles for Lots 26 and 29 advising the owners and subsequent owners thereof, of the following requirement to be complied with on a continuing basis*

The owners of this lot are required to meet the full cost of any fencing along the common boundary between the lot and the adjoining land used for reserve purposes

Engineering

52. *THAT sealed vehicle entrances to serve all confined vehicle entrance locations, all the existing entrances served from Lot 34 and all the proposed privateways shall be constructed in accordance with Council's Standard Specification Drawing **No's W436 and W437** (Diagram C). The entrance shall be sized in accordance with Drawing number W437. A culvert shall be installed to convey stormwater and to protect the Council road, **alternatively at the developer's representative discretion and approved by Council**, the culvert can be substituted by a swale being constructed to the same contour as the existing table drain. Where the vehicle entrance adjoins a kerb and channelling a 1.2m deep Commercial apron shall be provided in accordance with drawing number W435 and W436.*

53. ***THAT the proposed Privateways identified on the scheme plan as 'DE', 'DF', 'DG', 'DH', and 'DI' shall be constructed in accordance with Council's Standard Specification Drawing No's W439 and W440** or subsequent design to be approved at Councils discretion at the time of engineering approval. The type of surface to be provided (sealed or unsealed) shall be assessed at the engineering documents stage and shall comply with Council Minden Lifestyle rules and shall comply with the District Plan Rule in respect to **neighbour's** consent to unsealed surfaces.*

54. *THAT design and construction shall be carried out to ensure that stormwater overland flow paths are provided clear of the buildable area of each Lot and to take into account the runoff from areas of road, including adjacent catchment where relevant.*
55. *THAT the work required by conditions (52) and (54) shall be supervised and certified as **complete in accordance with the conditions by the consent holder's representative (refer Section 12.3.9a)** to the satisfaction of the Chief Executive Officer or duly Authorised Officer, except that a Chartered Professional Engineer shall be responsible for providing **certification of earthworks and road pavement construction in accordance with Council's Development Code.***

STAGE 3:

Financial Contributions

56. *THAT the following financial contributions be paid in respect of the subdivision:*

<i>a) Rural Rooding (Te Puke Ward)</i>	<i>6 x \$8763</i>	<i>\$52,578(+ GST)</i>
<i>b) District Wide Rooding</i>	<i>6 x \$1385</i>	<i>\$8,310(+ GST)</i>
<i>c) Recreation and Leisure</i>	<i>6 x \$7423</i>	<i>\$44,538(+ GST)</i>
<i>d) Ecological</i>	<i>6 x 501</i>	<i>\$3,006(+GST)</i>

57. *THAT with regard to Condition (40), the financial contributions calculated in accordance with the provisions of the Operative District Plan, shall be paid within full within two years of the date of commencement of the consent provided that:*
- a) Any financial contribution which is not paid in full within two years from the date of commencement of the consent shall be adjusted so that the amount of the financial contribution required by the resource consent shall be the amount calculated in accordance with the relevant formulae using the updated inputs to **those formulae as set out in Council's Annual Plan current at the date of payment.***
- b) Any financial contributions not paid within two years from the date of the commencement of the consent shall be (where applicable) paid prior to the issue of a Building Consent under the Building Act 2004, subject to the adjustments referred to in sub-paragraph (a) herein.*

Easements and Vesting

58. *The consent holder shall register an easement in gross in favour of the Council over **Lot 18 and 21 within the area shown as Area 'DK', 'EC', 'ED', 'EF', 'FA', 'FC' and 'FB' as shown on the plan of subdivision.***

*The easements in gross shall be shown on the survey plan prior to certification pursuant to Section 223 of the Resource Management Act 1991 and shall be shown as **a "Right of Way" and be registered on the survey plan under a "Memorandum of Easements in Gross."***

59. *The Lot 52 shall be vested in the Council as Local Purpose (Access) Reserve and be shown on the survey prior to certification pursuant to section 223 of the Resource Management Act 1991 shown on the scheme plan as.*

Consent Notices

60. Pursuant to Section 221 of the Resource Management Act 1991, a consent notice shall be registered on the Certificate of Titles for Lot 17, 18 and 19 advising the owners and subsequent owners thereof, of the following requirement to be complied with on a continuing basis

This lot includes land covered under Regulation 5(7) of the National Environmental Standard for Assessing and Managing Contaminants in Soil to Protect Human Health (NESCS). Disturbance of soil on the lot shall not occur unless:

- a) A preliminary site investigation or detailed site investigation is submitted to the Council to confirm soil contamination levels do not exceed NESCS levels; or*
- b) A consent for soil disturbance has been issued pursuant to the NESCS by the Council.*

61. Pursuant to Section 221 of the Resource Management Act 1991, a consent notice shall be registered on the Certificate of Titles for Lots 8, 9, 10, 17, 18 and 19 advising the owners and subsequent owners thereof, of the following requirement to be complied with on a continuing basis:

- a) The design and construction of any building or structure requiring a building consent in accordance with the Building Act 2004 shall comply with the recommendations Stratum Consultants Ltd Geotechnical Assessment Report Ref. 415542-M-E--C001, dated 27 July 2018.*
- b) The design and construction of any building or structure requiring a building consent in accordance with the Building Act 2004 shall demonstrate that firefighting capability is provided in accordance with the New Zealand Fire Service Firefighting Water Supplies Code of Practice SNZ PAS 4509:2008 (or any relevant superseding code).*

62. Pursuant to Section 221 of the Resource Management Act 1991, a consent notice shall be registered on the Certificate of Titles for Lots 9, 10 and 21 advising the owners and subsequent owners thereof, of the following requirement to be complied with on a continuing basis

The owners of this lot are required to meet the full cost of any fencing along the common boundary between the lot and the adjoining land used for reserve purposes

Engineering

63. THAT sealed vehicle entrances to serve all confined vehicle entrance locations, all the existing entrances served from Lot 34 and all the proposed privateways shall be constructed in accordance with Council's Standard Specification Drawing **No's W436 and W437 (Diagram C)**. The entrance shall be sized in accordance with Drawing number W437. A culvert shall be installed to convey stormwater and to protect the Council road, **alternatively at the developer's representative discretion and approved by Council**, the culvert can be substituted by a swale being constructed to the same contour as the existing table drain. Where the vehicle entrance adjoins a kerb and channelling a 1.2m deep Commercial apron shall be provided in accordance with drawing number W435 and W436.

64. *THAT the proposed privateways identified on the scheme plan as 'EA', 'EB', 'EC', 'ED, shall be constructed in accordance with Council's Standard Specification Drawing No's W439 and W440 or subsequent design to be approved at Councils discretion at the time of engineering approval. The type of surface to be provided (sealed or unsealed) shall be assessed at the engineering documents stage and shall comply with Council Minden Lifestyle rules and shall comply with the District Plan Rule in respect to neighbour's consent to unsealed surfaces.*
65. *THAT the bridge located on the proposed Privateway EC shall be replaced by an approved structure designed for the appropriate axle loads, handrail requirements, the appropriate storm environmental factors and to comply with the Building Act.*
66. *THAT design and construction shall be carried out to ensure that stormwater overland flow paths are provided clear of the buildable area of each Lot and to take into account the runoff from areas of road, including adjacent catchment where relevant.*
67. *THAT the consent holder shall submit confirmation from the Bay of Plenty Regional Council, that all necessary consents in relation to the subdivision have been granted. In the case where the Western Bay of Plenty District Council shall become the consent holder, any conditions of the consent will be subject to the approval of Council's Chief Executive Officer or duly Authorised Officer (This approval shall not be withheld unless the consent conditions are considered to be either unworkable or cost prohibitive in respect of future maintenance). That written confirmation shall be provided from the Bay of Plenty Regional Council that the works required by this condition have been completed to their satisfaction.*
68. *THAT the work required by conditions (63) and (66) shall be supervised and certified as complete in accordance with **the conditions by the consent holder's representative (refer Section 12.3.9a)** to the satisfaction of the Chief Executive Officer or duly Authorised Officer, except that a Chartered Professional Engineer shall be responsible for providing certification of **earthworks and road pavement construction in accordance with Council's Development Code.***

STAGE 4:

Financial Contributions

69. *THAT the following financial contributions be paid in respect of the subdivision:*

<i>a) Rural Roading (Te Puke Ward)</i>	<i>4 x \$8763</i>	<i>\$35,052(+ GST)</i>
<i>b) District Wide Roading</i>	<i>4 x \$1385</i>	<i>\$5,540(+ GST)</i>
<i>c) Recreation and Leisure</i>	<i>4 x \$7423</i>	<i>\$29,962(+ GST)</i>
<i>d) Ecological</i>	<i>4 x 501</i>	<i>\$2004(+GST)</i>

70. *THAT with regard to Condition (50), the financial contributions calculated in accordance with the provisions of the Operative District Plan, shall be paid within full within two years of the date of commencement of the consent provided that:*
- c) Any financial contribution which is not paid in full within two years from the date of commencement of the consent shall be adjusted so that the amount of the financial contribution required by the resource consent shall be the amount*

calculated in accordance with the relevant formulae using the updated inputs to those formulae as set out in Council's Annual Plan current at the date of payment.

- d) Any financial contributions not paid within two years from the date of the commencement of the consent shall be (where applicable) paid prior to the issue of a Building Consent under the Building Act 2004, subject to the adjustments referred to in sub-paragraph (a) herein.*

Easements and Vesting

- 71. The consent holder shall register an easement in gross in favour of the Council over Lot 7 **the area shown as Area 'AA' and 'AB', 'as shown on the plan of subdivision.***

The easements in gross shall be shown on the survey plan prior to certification pursuant to Section 223 of the Resource Management Act 1991 and shall be shown as a "Right of Way" and be registered on the survey plan under a "Memorandum of Easements in Gross."

Consent Notices

- 72. Pursuant to Section 221 of the Resource Management Act 1991, a consent notice shall be registered on the Certificate of Titles for Lots 13, 14, 15 and 16 advising the owners and subsequent owners thereof, of the following requirement to be complied with on a continuing basis:*

- a) The design and construction of any building or structure requiring a building consent in accordance with the Building Act 2004 shall comply with the recommendations Stratum Consultants Ltd Geotechnical Assessment Report Ref. 415542-M-E--C001, dated 27 July 2018.*
- b) The design and construction of any building or structure requiring a building consent in accordance with the Building Act 2004 shall demonstrate that firefighting capability is provided in accordance with the New Zealand Fire Service Firefighting Water Supplies Code of Practice SNZ PAS 4509:2008 (or any relevant superseding code).*

- 73. Pursuant to Section 221 of the Resource Management Act 1991, a consent notice shall be registered on the Certificate of Titles for Lot 15 advising the owners and subsequent owners thereof, of the following requirement to be complied with on a continuing basis*

The owners of this lot are required to meet the full cost of any fencing along the common boundary between the lot and the adjoining land used for reserve purposes

Engineering

- 74. THAT sealed vehicle entrances to serve all confined vehicle entrance locations, all the existing entrances served from Lot 34 and all the proposed privateways shall be constructed in accordance with Council's Standard Specification Drawing **No's W436 and W437 (Diagram C)**. The entrance shall be sized in accordance with Drawing number W437. A culvert shall be installed to convey stormwater and to protect the Council road, **alternatively at the developer's representative discretion and approved by Council**, the culvert can be substituted by a swale being constructed to the same contour as the existing table drain. Where the vehicle entrance adjoins a kerb and channelling a 1.2m*

deep Commercial apron shall be provided in accordance with drawing number W435 and W436.

75. *THAT the proposed privateways **identified on the scheme plan as 'AA', 'AB', 'AC', 'AD', 'AE' and 'AF'** shall be constructed in accordance with Council's Standard Specification **Drawing No's W439 and W440**, or subsequent design to be approved at Councils discretion at the time of engineering approval. The type of surface to be provided (sealed or unsealed) shall be assessed at the engineering documents stage and shall comply with Council Minden Lifestyle rules and shall comply with the District Plan Rule in respect to **neighbour's** consent to unsealed surfaces.*
76. *THAT design and construction shall be carried out to ensure that stormwater overland flow paths are provided clear of the buildable area of each Lot and to take into account the runoff from areas of road, including adjacent catchment where relevant.*
77. *THAT a storm water connection shall be provided within the property boundary of proposed Lots 13 and 14 or any other allotments which can not dispose of storm water on site in accordance with Council's Development Code.*
78. *THAT storm water easement be created over private storm water connections where they cross over lots and that this be shown on the survey plan.*
79. *THAT the work required by conditions (74) and (78) shall be supervised and certified as complete in accordance with the conditions by the consent **holder's representative (refer Section 12.3.9a)** to the satisfaction of the Chief Executive Officer or duly Authorised Officer, except that a Chartered Professional Engineer shall be responsible for providing certification of earthworks and road pavement **construction in accordance with Council's Development Code.***

ADDITIONAL WALKWAY CONSTRUCTION CONDITION

THAT the proposed walkways to be vested and/or covered by easement in gross are constructed to a minimum width of 1.5m and finished to a compacted all weather surface. Fencing of the walkway corridor shall include a minimum 5 wire rural fence, except that where a walkway co-aligns with a privateway, fencing shall be limited to the side of walkway opposite the privateway carriageway only.