

NOTES:

- As of 01 / 01 / 1990 the Tauranga City Council adopted L & S Datum (Moturiki Othometric)

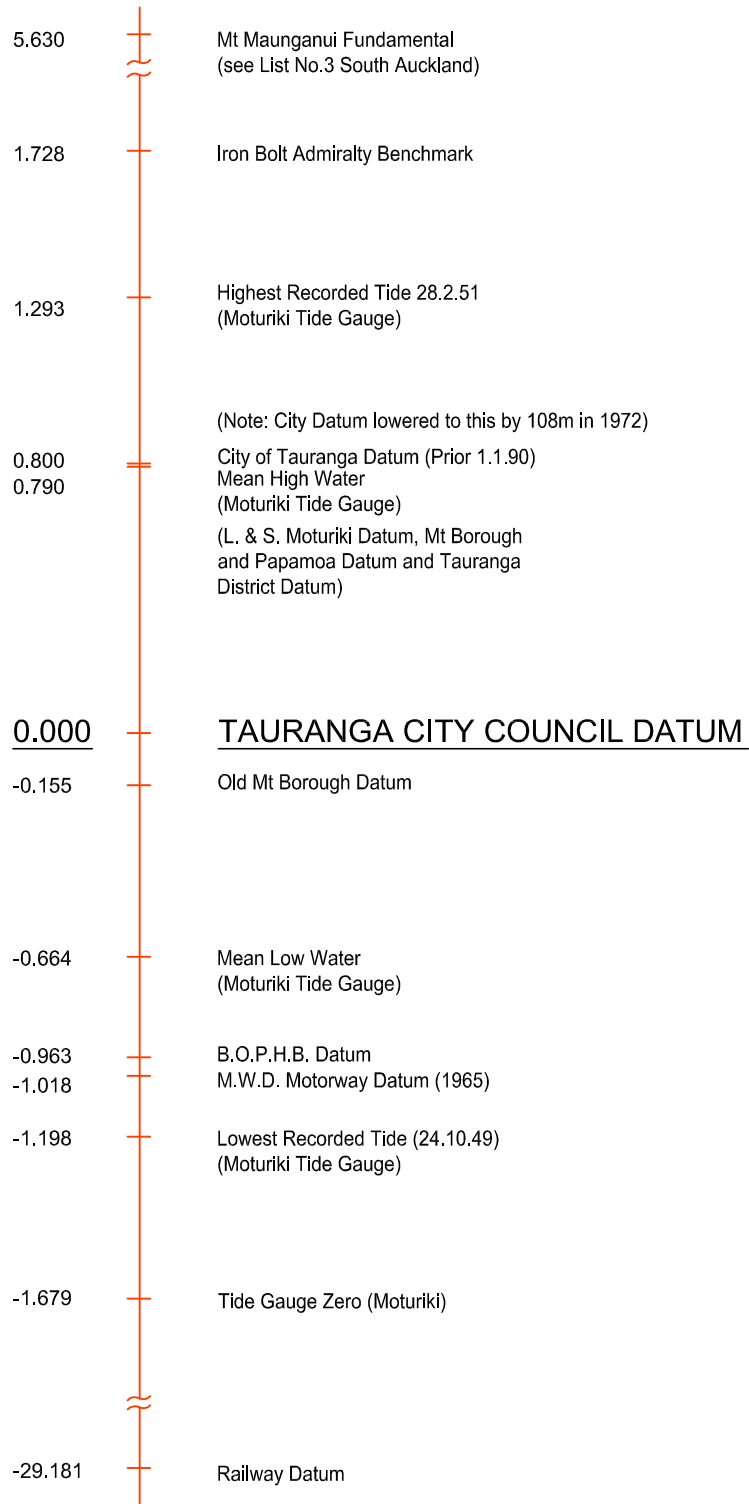

RELATIVITY OF DATUM LEVELS

QA-01

	Existing (0.25mm)	Proposed (0.5mm)
Peg Line (Traverse)		
Boundary Line		
Centre Line (design)		
Kerb & Channel		
Edge of Seal		
Fence		
Telephone Cable		
Power Cable		
Water Main		
Sluice Valve		
Fire Hydrant		
Blank Cap		
Main Reducer		
Stormwater Main		
Stormwater Manhole		
Sump		
Sanitary Sewer Main		
Sanitary Sewer Manhole		
Sewer Plug / Rodding Eye		
Pumping Station / Rising Main		
Gas Main		
Telephone Pole		
Power Pole		
Telephone and Power Pole		
Street Light		

NOTES:

1. WBOPDC encourages alternative item location by (x,y) coordinates local or NZMG with Z values.

SEWER

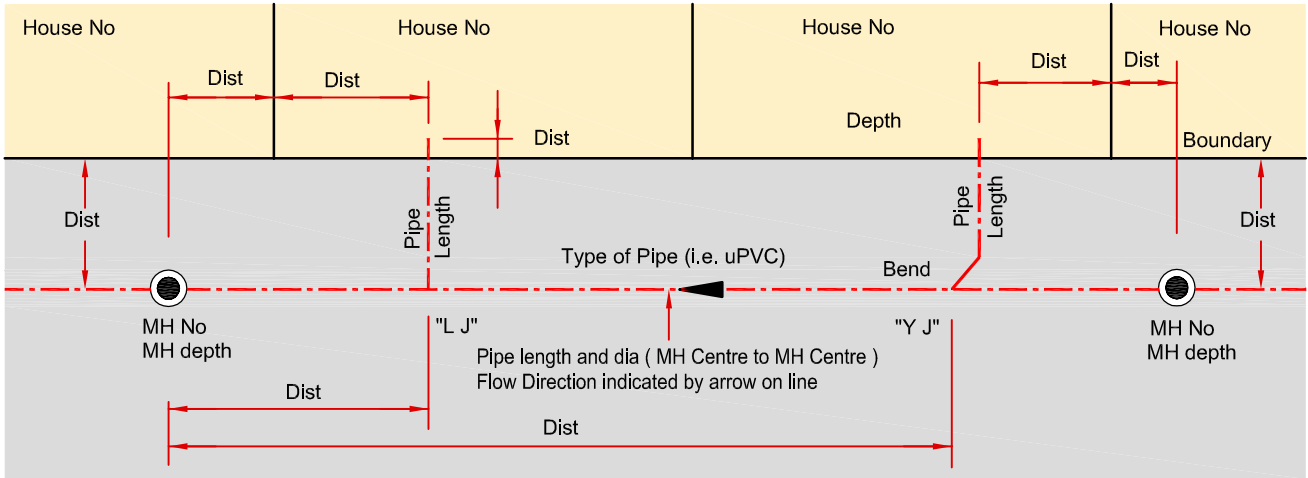

WATER

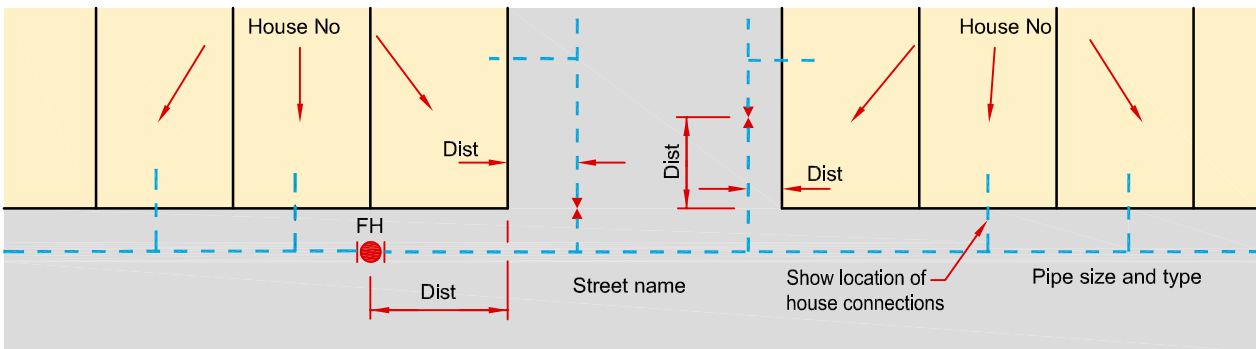

STORMWATER

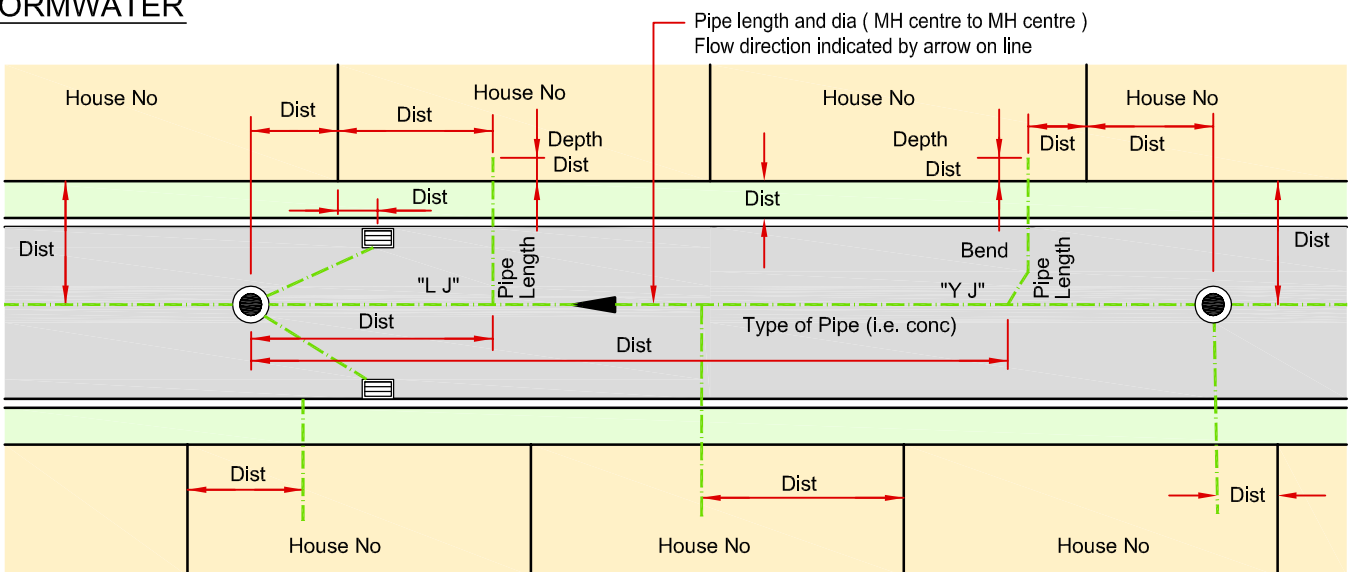

AS BUILT DIMENSIONING

QA-03

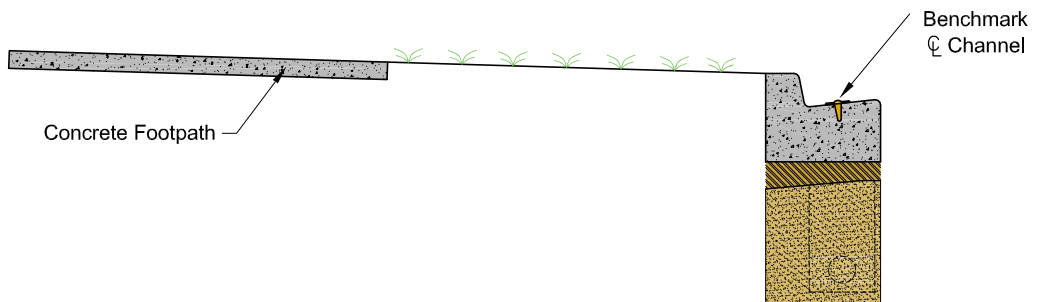
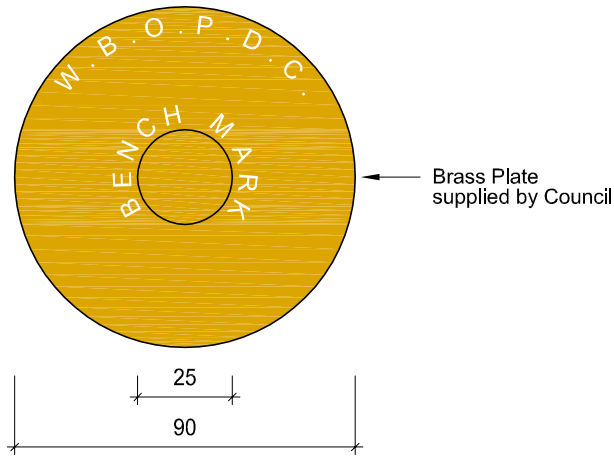
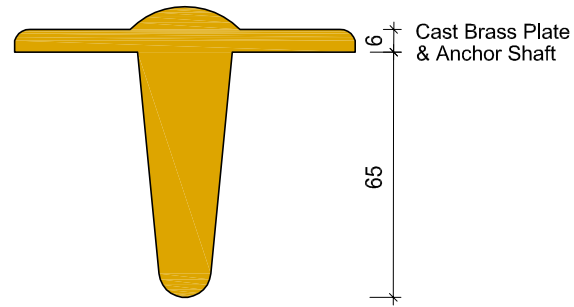

BENCHMARK IN K & C

QA-04

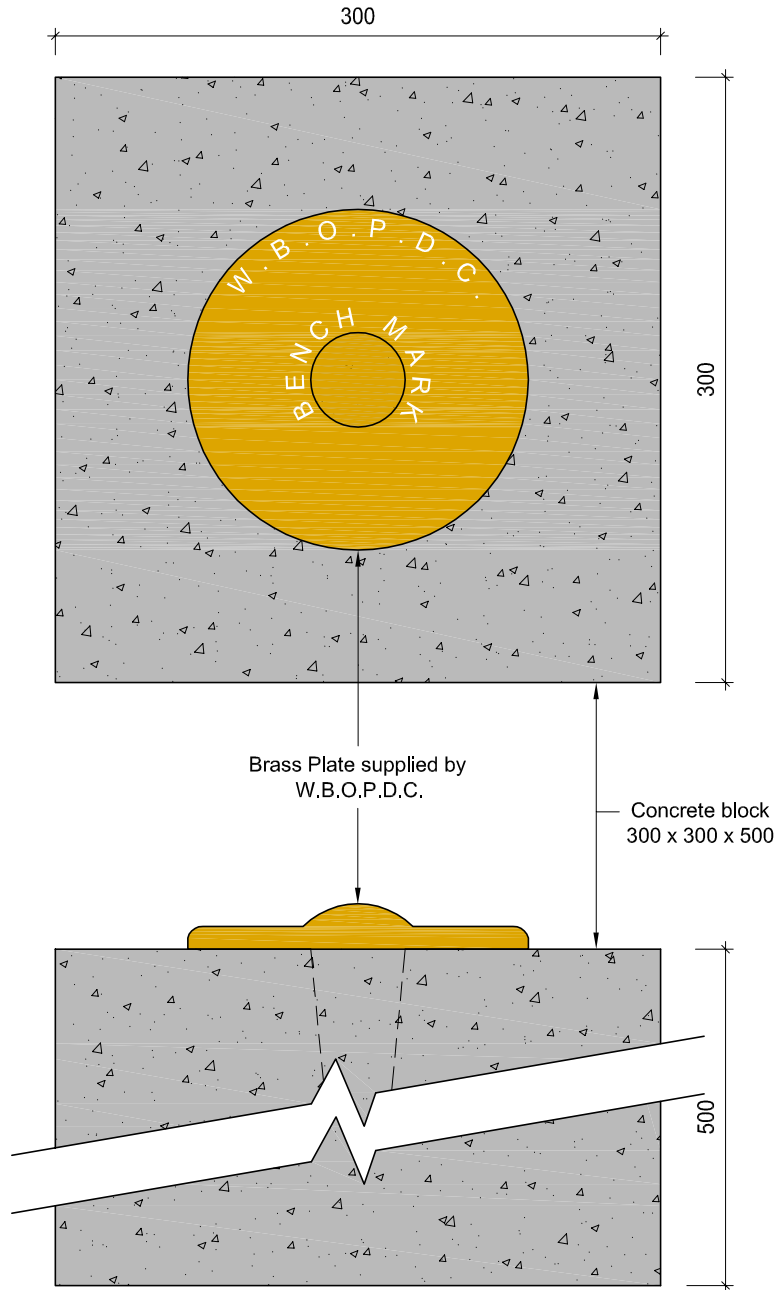

BENCHMARK IN BLOCK

QA-05

DEVELOPMENT CODE

VERSION 1
AUG 09

1